



INSTALLATION & SERVICING

HEAT PUMP CYLINDER

When replacing any part on this appliance, use only spare parts that you can be assured conform to the safety and performance specification that we require. Do not use reconditioned or copy parts that have not been clearly authorised by Ideal Boilers.

For the very latest copy of literature for specification and maintenance practices visit our website www.idealboilers.com where you can download the relevant information in PDF format.

GPL006-IU-Iss06-03/20



These instructions should be read in conjunction with the installation/servicing instructions issued by the manufacturer of the heat source being used.

Any installation must be in accordance with the relevant requirements of the Gas Safety Regulations, Building Regulations, I.E.E. Wiring Regulations and the Water Fitting Regulations (England and Wales) or Water Byelaws (Scotland). It should be read in accordance with the relevant recommendations of the following:

BS 6798; BS EN 12828, BS EN 12831, BS EN 14336; BS 5546;

BS 5440:1; BS 5440:2; CP 331:3

BS EN 806-1 to 5, BS EN 8558:2011; BS EN 1458-1:2011 and BS 7593:2006

Ideal HP is covered by Section G3 of the Building Regulations (England and Wales) Technical Standard P3 (Scotland) and Building Regulation P5 (Northern Ireland). Compliance can be achieved via a Competent Person Self Certification Scheme or notification of installation to the Local Authority Building Control Department.

It must be installed by a competent person as defined by the relevant regulations. Manufacturers notes must NOT be taken as over-riding statutory obligations.

This appliance is not intended for use by persons (including children) with reduced physical, sensory or mental capabilities, or lack of experience and knowledge unless they have been given supervision or instruction concerning use of the appliance by a person responsible for their safety. Children should be supervised at all times to ensure they do not play with the appliance.

This information is provided to assist generally in the selection of equipment. Responsibility for selection and specification of our equipment must however remain that of our customer and any experts or consultants concerned with the installation(s).

Please note: that we do not therefore accept any responsibility for matters of design selection or specification, for the effectiveness of an installation or system containing one of our products unless specifically requested to do so in writing.

All goods are sold subject to our Conditions of Sale which are set out at the rear of this specification. In the interest of continuously improving the Ideal HP range, Ideal Boilers reserve the right to modify the product without notice, and in these circumstances this booklet, which is accurate at the time of printing, should be disregarded. An updated set of Instructions will be produced and supplied with new appliances and will be made available for other appliances on request.

Ideal HP is produced under an ISO 9001:2008 Quality Management System approved by BSI.



Benchmark places responsibilities on both manufacturers and installers. The purpose is to ensure that customers are provided with the correct equipment for their needs, that it is installed, commissioned and serviced in accordance with the manufacturers instructions by competent persons and that it meets the requirements of the appropriate Building Regulations. The Benchmark Checklist can be used to demonstrate compliance with Building Regulations and should be provided to the customer for future reference.

Installers are required to carry out installation, commissioning and servicing work in accordance with the Benchmark Code of Practice which is available from the Heating and Hot Water Industry Council who manage and promote the Scheme. Visit www.centralheating.co.uk for more information.

Section	Page
DESIGN	
Description	3
Technical Information	4
System Design	6
INSTALLATION	
Installation	8
Commissioning	18
USER INSTRUCTIONS	19
SERVICING AND MAINTENANCE	
Servicing and Maintenance	19
Fault Finding	21
Short Parts List	22
APPENDIX	
Appendix A	24
Appendix B	25
Terms & Conditions	26
Notes	27
Benchmark Checklist	28
Benchmark Service Record	29

Manufacturer: Ideal Boilers

Maximum inlet pressure to Pressure reducing valve	12 bar
Operating pressure (PRV setting)	3 bar
Expansion vessel charge pressure	3 bar
Expansion relief valve setting	4.5 bar
Opening pressure of P & T Relief Valve	6 bar
Opening temperature of P & T Relief Valve	95°C
Energy cut-out thermostat setting	85°C
Max. working pressure - Heat pump heat exchanger	3 bar
Immersion heater rating	3kW, 240V AC

All cylinders are manufactured in accordance with the requirements of BS EN 12897. The tundish must be positioned so that it is visible to the occupant and is away from electrical devices.

Components supplied with Ideal HP:

- Cold water inlet PRV combination valve/expansion relief
- Lift up pressure and temperature relief valve
- Control thermostat
- Energy cut-out thermostat
- Energy cut-out motorised valve (indirects only)
- Tundish
- 3kW Immersion heater including control and cut out thermostats
- Drain elbow and 90 degree elbow
- Expansion vessel/mounting bracket
- Technical/user product literature

In any situation where the volume of heated pipework (eg. secondary circulation pipes or manifold pipework for multiple units) exceeds 10 litres, then an additional expansion vessel must be fitted to accommodate the extra expansion volume.

Handling Before Installation

Ideal HP must be handled with care and stored the correct way up in a dry place. Any manual handling/lifting operations will need to comply with the requirements of the Manual Handling Operations Regulations issued by the H.S.E. The appliance can be moved using a sack truck on the rear face although care should be taken and the route should be even. In apartment buildings containing a number of storeys we would recommend that the appliances are moved vertically in a mechanical lift. If it is proposed to use a crane, expert advice should be obtained regarding the need for slings, lifting beams etc.

A specific manual handling assessment is shown in Appendix B at the rear of this manual.

The Environment

This product has been manufactured using many recyclable materials, including the approved HCFC/CFC free polyurethane foam insulation. At the end of its useful life, it should be disposed of at a Local Authority Recycling Centre, to maximise the products full environmental benefits.

Maintenance

Modifications should not be made to this product. Replacement parts, including immersion heaters, should be purchased from Ideal Boilers, or agents approved by them. Unvented hot water storage vessels need regular routine checks, and these are detailed below. It is for this reason that this manual must always be left with the Ideal HP.

It is essential that these checks be carried out at the time of annual heat pump maintenance by a qualified installer:

1. Manually open the relief valves in turn, and check that water is discharged from the valves and runs freely through the tundish and out at the discharge point. Ensure that the valves re-seat satisfactorily. (Note - the water may be very hot).
2. It is important to check that the discharge pipework is carrying the water away adequately. Check for blockages etc. if it is not.
3. Turn the mains water off and remove and clean the strainer element in the Pressure Reducing Valve.
4. Check the charge pressure in the expansion vessel and repressurise if required
5. Re-fill the system and ensure that all relief valves have re-seated.
6. The Benchmark Service Record should be updated at each service.
7. Check the water pressure downstream of the combination valve is 3 bar in static condition.
8. Check and if necessary, descale the heat exchanger in hard water areas ie. above 200ppm (mg/l).

Note:

The cylinder is factory fitted with a lift up temperature & pressure relief valve that must not be used for any other purpose or removed.

The cylinder is factory fitted with immersion heaters with thermal cut outs. Immersions without thermal cut outs must not be fitted.

DESIGN

Table 1

Ideal HP Model			HP180IND	HP210IND	HP250IND	HP300IND
Product Stock Code			IDEPLUHP180	IDEPLUHP210	IDEPLUHP250	IDEPLUHP300
Energy efficiency class			B	B	C	C
Heat loss		watts	55	62	74	86
		kWh/24h	1.32	1.49	1.78	2.06
Capacity - total volume		litres	178	208	248	287
Volume heated by IH		litres	158	189	229	268
Weight - empty/full		kg	34/212	38/246	43/291	47/334
Pressure regulating valve setting		bar	3	3	3	3
Expansion relief valve setting		bar	4.5	4.5	4.5	4.5
Temperature setting (P&T valve)		°C	95	95	95	95
Pressure setting (P&T valve)		bar	6	6	6	6
Expansion vessel size (volume)		litres	18	24	24	35
Expansion vessel initial charge pressure		bar	3	3	3	3
Height		mm	1306	1494	1744	1990
Diameter		mm	550	550	550	550
Hot Supply	A	mm	1365	1553	1803	2050
P & T valve	B	mm	1064	1252	1502	1748
22mm secondary return	C	mm	-	1141	1353	1562
28mm primary flow	D	mm	1060	1245	1270	1290
HP control thermostat	E	mm	454	516	600	682
28mm primary return	F	mm	290	275	300	320
Cold feed	G	mm	220	220	220	220
3kW immersion heater	H	mm	220	220	220	220
Dual control / Overheat thermostat	I	mm	454	516	600	682
Primary heat exchanger surface area ¹		m ²	2.5	3	3	3
Primary heat exchanger thermal rating ¹		kW	16.74	17.91	15.93	13.18
Primary heat exchanger pressure loss ¹		bar	0.04	0.032	0.032	0.032
Heat up time from 15°C to 50°C ²		min	18.02	20.47	31.57	42.5
Average domestic hot water temperature ¹		°C	46.95	46.77	48.44	42.06

1. Measured at 0.25 l/s primary flow rate 2. Measured at 0.25 l/s primary flow rate and at 55°C flow temperature

NOTES

1. Recovery times base on Primary Coil/I.H. duty (ie. assumes the heat pump output is adequate).

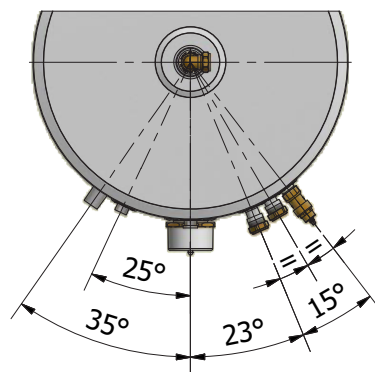
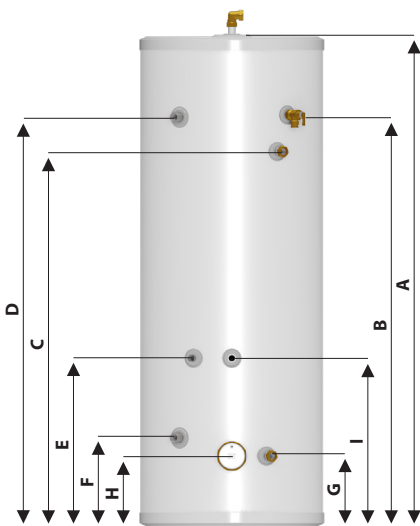

NOTES

1. Not all models - see table 2.
2. Recovery times based on Primary Coil/I.H. duty (ie. assumes the heat pump output is adequate).
3. All connections are supplied with compression fittings for direct connection to copper pipework.

Table 3

Ideal HP Slimline Model			HP180SL	HP210SL
Product Stock Code			IDEPLUHP180SL	IDEPLUHP210SL
Energy efficiency class			C	C
Heat loss		watts	67	74
		kWh/24h	1.61	1.77
Capacity - total volume		litres	183	202
Volume heated by IH		litres	166	186
Weight - empty/full		kg	38/219	40/237
Pressure regulating valve setting		bar	3	3
Expansion relief valve setting		bar	4.5	4.5
Temperature setting (P&T valve)		°C	95	95
Pressure setting (P&T valve)		bar	6	6
Expansion vessel size (volume)		litres	18	24
Expansion vessel initial charge pressure		bar	3	3
Height	A	mm	1791	1963
Diameter	B	mm	475	475
22mm secondary return	C	mm	-	1551
22mm compression cold feed	D	mm	220	220
P & T valve	E	mm	1565	1737
28mm primary return	H	mm	290	300
28mm primary flow	I	mm	1545	1585
HP control thermostat	J	mm	617	674
Dual CT & OHT pocket	K	mm	617	674
3kW immersion heater height	N	mm	220	220
Primary heat exchanger surface area		m ²	3.01	3.01
Primary heat exchanger thermal rating ¹		kW	32.8	31.2
Primary heat exchanger pressure loss ¹		bar	0.018	0.018
Heat up time from 15°C to 60°C ²		min	33	41

1. Measured at 0.25 l/s primary flow rate

2. Measured at 0.25 l/s primary flow rate and at 82°C flow temperature

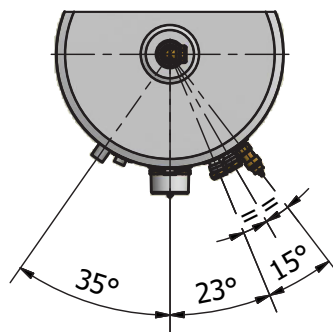
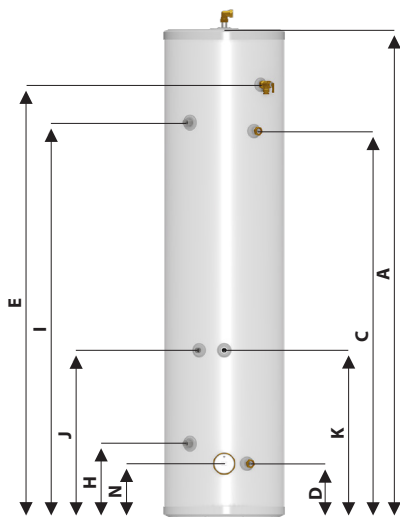

NOTES

1. Not all models - see table 3.
2. Recovery times based on Primary Coil/I.H. duty (ie. assumes the heat pump output is adequate).
3. All connections are supplied with compression fittings for direct connection to copper pipework.

DESIGN

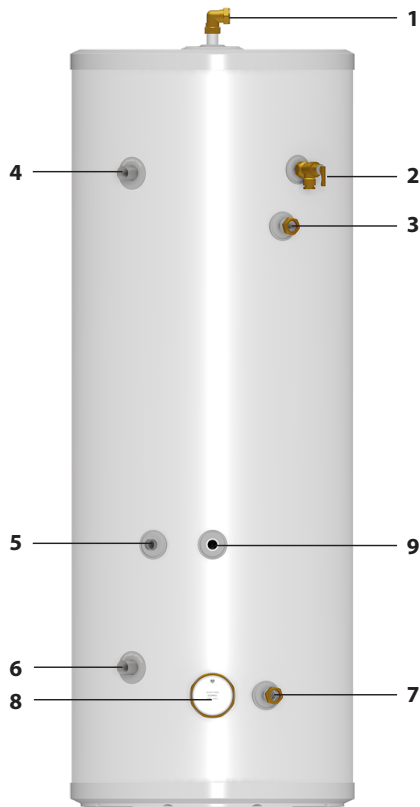

Ideal HP

Basic Appliance

1. Hot water draw off (22mm) compression
2. Lift up temperature & pressure relief valve 95°/6 bar
3. Hot water secondary return (22mm compression, not fitted to smaller sizes, see table 2)
4. Primary flow (28mm plain pipe)
5. HP control thermostat
6. Primary return (28mm plain pipe)
7. Cold feed (22mm compression)
8. Immersion heater 1 $\frac{3}{4}$ " BSP 3kW
9. Overheat stat

Part G3 loose components supplied in a separate box'

- A. Combination inlet group incorporating pressure reducing valve, strainer, check valve, balance cold take off point, expansion relief valve and expansion vessel connection points.
- B. Potable expansion vessels c/w integral wall bracket
- C. Tundish
- D. Drain elbow
- E. Compression fittings
- F. Overheat thermostat
- G. Three port (28mm) zone valve for primary circuit

DESIGN

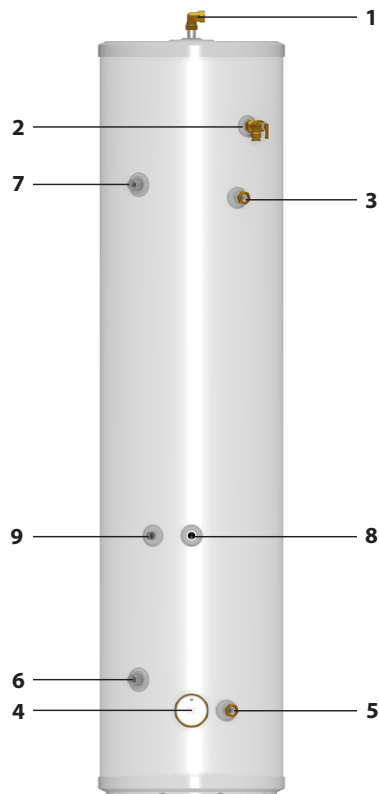

Ideal HP Slimline

Basic Appliance

1. Hot water draw off (22mm compression)
2. Lift up temperature & pressure relief valve 95°/6 bar
3. Hot water secondary return (22mm compression, 210 litre model only)
4. Immersion heater 1 3/4" BSP 3kW
5. Cold feed (22mm compression)
6. Primary return (28mm)
7. Primary flow (28mm)
8. Overheat stat
9. HP control thermostat

Part G3 loose components supplied in a separate box'

- A. Combination inlet group incorporating pressure reducing valve, strainer, check valve, balance cold take off point, expansion relief valve and expansion vessel connection points.
- B. Potable expansion vessels c/w integral wall bracket
- C. Tundish
- D. Drain elbow
- E. Compression fittings
- F. Overheat thermostat
- G. Three port (28mm) zone valve for primary circuit

INSTALLATION

Ideal HP is a range of unvented hot water storage cylinders, manufactured in the latest high quality duplex stainless steel. They are designed to provide mains pressure hot water and are supplied as a package which complies with Section G3 of the Building Regulations. The appliance is extremely well insulated using high density HCFC free foam insulation with an ozone depleting potential (ODP) of zero and a global warming potential (GWP) of 2. It is fitted with all necessary safety devices and supplied with all the necessary control devices to make installation on site as easy as possible.

Ideal Heat Pump (HP) and Slimline models:

The Ideal HP and Slimline cylinders unvented hot water storage cylinders fitted with a high efficiency coil. The coil has a low pressure loss due to it being a multiple pass coil which enable high flow rates to be achieved through it. In addition due to the coil being corrugated the heat transfer rate is higher than that of plain tube coil.

The cylinder has been specifically designed for heat pump applications. It incorporates an immersion heater at the base of the unit which enables pasteurisation of the water. This should be done on a regular basis in line with HWA guidance..

The slimline has been designed to enable it to fit into tighter locations.

Important notes:

1. All Ideal HP models are suitable for both open vented and sealed primary systems.
2. When used with a sealed primary heating system, the heat pump must incorporate its own over heat thermostat.
3. Ideal HP models must not be used with uncontrolled heat source or steam as the heat source.
4. Heat pumps can normally only heat the domestic hot water to between 45 – 50°C, therefore provision should be made to periodically heat the cylinder to above 60°C to prevent growth of legionella.
5. The cold supply elbow c/w drain tapping must be fitted as shown in figures 1 & 2. A flexible hose can then be connected to the drain tapping and providing the hose runs below the lowest level of the cylinder, then all the water content can be drained out by the syphonic action.

INSTALLATION

General Design Considerations

The cupboard footprint needs to be at least 650mm square for units up to 300 litres.

The base chosen for the cylinder should be level and capable of supporting the weight of the unit when full of water as shown in General Data. The discharge pipework for the safety valves must have a minimum fall of 1 : 200 from the unit to a safe discharge point. All exposed pipework and fittings on the cylinder should be insulated, and the unit should NOT be fixed in a location where the contents could freeze.

In new systems, pipes should be insulated to comply with building regs, the maximum permissible heat loss is indicated in the table opposite, and labelled accordingly as follows:

- i. Primary circulation pipes for domestic hot water circuits should be insulated through their length, subject only to practical constraints imposed by the need to penetrate joists and other structural elements.
- ii. All pipes connected to hot water storage vessels, including the vent pipe, should be insulated for at least 1 metre from their points of connection to the cylinder (or they should be insulated up to the point where they become concealed).

In replacement systems, whenever a boiler or hot water storage vessel is replaced in an existing system, any pipes that are exposed as part of the work or are otherwise accessible should be insulated as recommended for new systems, or to some lesser standard where practical constraints dictate.

The pipe connecting the boiler flow to the appliance must not be less than 22mm copper or equivalent.

Insulation of pipework	
Pipe outside diameter	Maximum heat loss
15mm	7.89W/m
22mm	9.12W/m
28mm	10.07W/m
35mm	11.08W/m

Further guidance on converting heat loss limits to insulation thickness for specific thermal conductivities is available in TIMSA "HVAC guidance for achieving compliance with Part L of the Building Regulations".

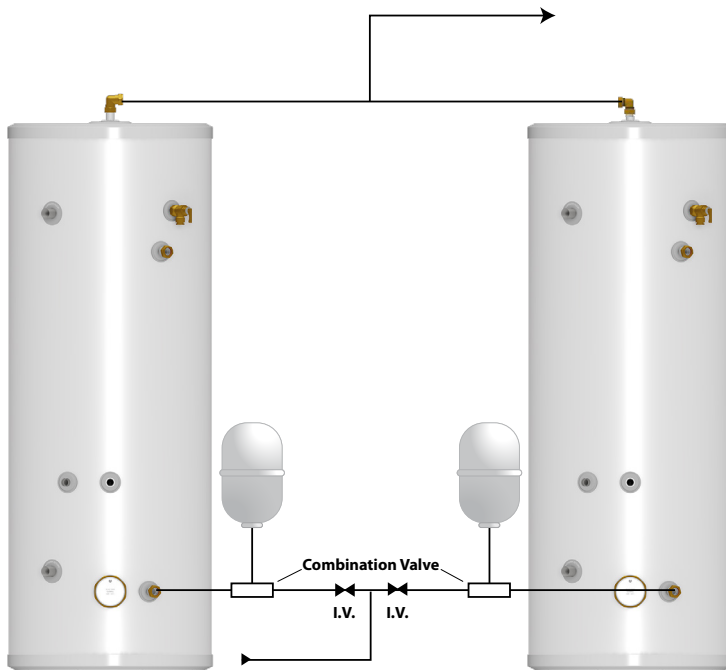

If two Ideal HP cylinders are coupled together the secondary inlet and outlet pipes must be balanced. The units must be fitted on the same level.

Note: No valves must be fitted between the expansion vessel and the storage cylinder(s).

Mains Water Supply

Existing properties with a 15mm supply will be satisfactory provided the local mains pressure is good, but should be confined to single bathroom properties. For new properties where simultaneous demand is required to more than one bathroom or a bathroom and one or more en-suites, the communication and service pipe into the dwelling should be a minimum of 22mm (usually in the form of a 25mm MDPE supply). The optimum performance is achieved if the inlet pressure is 3 bar dynamic. However, the Ideal HP will function with lower inlet pressures, but this will reduce the performance. There should be a flow of at least 30 litres per minute or above available into the property. Normally Ideal HP provides well in excess of 40 litres/min in most conditions. Flow rates for ALL mains pressure systems are subject to district pressures and system dynamic loss. Particularly on larger properties with more than one bathroom, the pipe sizes should be calculated in accordance with BS EN 806-3:2006 and BS 8558:2011.

INSTALLATION

Ideal HP and HP Slimline Model Selection Guide		
Dwelling type		Suggested model
Number of bedrooms	Number of bathrooms and shower rooms	
1-3	1 bathroom	HP180IND HP180SL
2-3	1 bathroom + 1 shower room	HP180IND HP180SL
2-3	1 bathroom + 2 shower rooms	HP180IND HP180SL
2-4	2 bathrooms + 1 shower room	HP210IND HP210SL
2-4	2 bathrooms + 2 shower rooms	HP250IND
3-5	2 bathrooms + 2 shower rooms	HP300IND

Model Selection

The suggested model sizes shown in the table opposite are based on a typical daily hot water usage and on the assumption that the heat pump will heat the domestic hot water to about 50°C. For higher specification, an increase of one model size should be considered.

When sizing the hot water cylinder, please use MCS guidelines in MIS3005 and also refer to BS EN 806:1-5 AND BS EN 8558.

INSTALLATION

Ideal HP/Heat Pump Selection Guide																
1 - Flow rates in various units for comparison with heat pump manufacturers data																
m ³ /h	0.50	0.75	1.00	1.25	1.50	1.75	2.00	2.25	2.50	2.75	3.00	3.25	3.50	3.75	4.00	4.25
l/min	8.33	12.50	16.67	20.83	25.00	29.17	33.33	37.50	41.67	45.83	50.00	54.17	58.33	62.50	66.67	70.83
l/sec or kg/s	0.14	0.21	0.28	0.35	0.42	0.49	0.56	0.63	0.69	0.76	0.83	0.90	0.97	1.04	1.11	1.18
2 - Velocity in pipe (limited to 1 m/s maximum) for pipe sizing																
m/s in 22mm	0.37	0.55	0.73	0.91	-	-	-	-	-	-	-	-	-	-	-	-
m/s in 28mm	0.23	0.34	0.45	0.56	0.68	0.79	0.90	-	-	-	-	-	-	-	-	-
m/s in 35mm	0.14	0.22	0.29	0.36	0.43	0.51	0.58	0.65	0.72	0.79	0.87	0.94	-	-	-	-
m/s in 42mm	0.10	0.15	0.20	0.25	0.30	0.35	0.40	0.45	0.50	0.55	0.60	0.65	0.70	0.75	0.80	0.85
3 - Operating power of heat exchanger suitable for cylinder based on a 5 degree temperature difference																
kW @ 5K dt	3-4	4-6	5.5-8	7-10	8-12	10-14	11-16	13-18	14-20	16-22	17-24	18-26	20-28	21-30	23-32	24-34
180HP							-	-	-	-	-	-	-	-	-	-
180HP Slim							-	-	-	-	-	-	-	-	-	-
210HP								-	-	-	-	-	-	-	-	-
210HP Slim								-	-	-	-	-	-	-	-	-
250HP								-	-	-	-	-	-	-	-	-
300HP												-	-	-	-	-
4 - Pressure loss (bar) for each flow rate above in the available coil combinations																
180HP	0.010	0.027	0.053	0.092	0.143	0.207	0.286	0.381	0.491	0.618	0.763	0.927	1.109	1.310	1.532	1.774
180HP Slim	0.004	0.010	0.018	0.030	0.044	0.062	0.083	0.108	0.136	0.167	0.202	0.241	0.283	0.329	0.379	0.432
210HP	0.017	0.040	0.074	0.118	0.173	0.239	0.316	0.405	0.505	0.617	0.741	0.877	1.025	1.184	1.356	1.540
210HP Slim	0.004	0.010	0.018	0.030	0.044	0.062	0.083	0.108	0.136	0.167	0.202	0.241	0.283	0.329	0.379	0.432
250HP	0.006	0.015	0.028	0.045	0.067	0.093	0.124	0.159	0.200	0.245	0.295	0.350	0.410	0.475	0.545	0.620
300HP	0.008	0.019	0.036	0.058	0.086	0.120	0.160	0.206	0.259	0.318	0.384	0.457	0.536	0.623	0.716	0.816

Ideal HP/Heat Pump Selection Guide

The table above can be used to match heat pumps to heat pump cylinders.

To use, first obtain the maximum flow rate from the heat pump manufacturer's instructions, match this to the flow rates in section 1 and follow this flow rate's column down through the other sections.

Section 2 shows the velocity in the pipe work of different diameters at this flow rate. A maximum flow velocity of 1m/s has been chosen to limit flow noise. Use this section to choose the correct pipe diameter.

Section 3 shows the maximum operating power of the coils in the cylinder. Shaded squares show the range of operating powers suitable for a cylinder in either of its set ups.

Section 4 shows the pressure loss across the coils at this flow rate for all cylinders in both configurations.

INSTALLATION

General Restrictions

- The highest hot or cold water draw off point should not exceed 10 metres above the Pressure Reducing Valve.
- An ascending spray type bidet or any other appliance with a Class 1 back-syphonage risk requiring a type A air gap should not be used.
- Ideal HP should not be used where steam is the primary heating medium, or in a situation where maintenance is likely to be neglected.
- Unvented cylinders are not suitable for use with solid fuel boilers.
- If the supply to the mixer fittings (other than a dual outlet type) is not taken from the balanced supply the system will become over pressurized and cause the pressure relief valve to discharge. Over time this could also cause the premature failure of the appliance itself which will not be covered by the warranty.**
- In larger properties with a number of bathrooms/en-suites and long pipe runs we would recommend that the balance cold supply is provided with its own pressure reducing valve and is not taken from the balanced cold connection on the combination valve. In this case it will also be necessary to fit a small expansion vessel on the balanced cold water system to accommodate the pressure rise caused by the increase in temperature of the balanced cold water.
- Check the performance requirements of the terminal fittings with regard to flow/pressure are suitable.

Shower Fittings

Aerated taps are recommended to prevent splashing. Any type of shower mixing valve can be used as long as both the hot and cold supplies are mains fed. However, all mains pressure systems are subject to dynamic changes particularly when other hot and cold taps/showers are opened and closed, which will cause changes in the water temperature at mixed water outlets such as showers. For this reason and because these are now no more expensive than a manual shower we strongly recommend the use of thermostatic showers with this appliance. These must be used in 3 storey properties where the impact on pressure/temperature of opening another tap in the system is greater than normal. The shower head provided must also be suitable for mains pressure supplies.

Pipe Layout

In all mains pressure installations it is important to remember that the incoming cold supply must be shared between all terminal fittings. It is important that a 22mm supply is brought to the appliance and a 22mm take-off is continued at least to the bath. If there are two baths, 28mm pipework should be considered. One metre of smaller diameter pipework, or flow restrictors, should be provided on the final connection to all outlets so as to balance the water available. In any event the distribution pipework should generally be in accordance with BS EN 806-1 to 5.

Plastic Pipework

This appliance is suitable for use with plastic pipework as long as the material is recommended for the purpose by the manufacturer and is installed fully in accordance with their recommendations.

Secondary Hot Water Circulation

All models 210 and above are fitted with a secondary return tapping as standard (see table 1 for details). If fitted, an extra expansion vessel may be necessary. A non-return valve MUST be FITTED near the return connection. No valve or terminal fitting should be installed between the non return valve and the cylinder. (See schematic arrangement on page 16.) All pipes kept hot by the secondary circulation should be insulated.

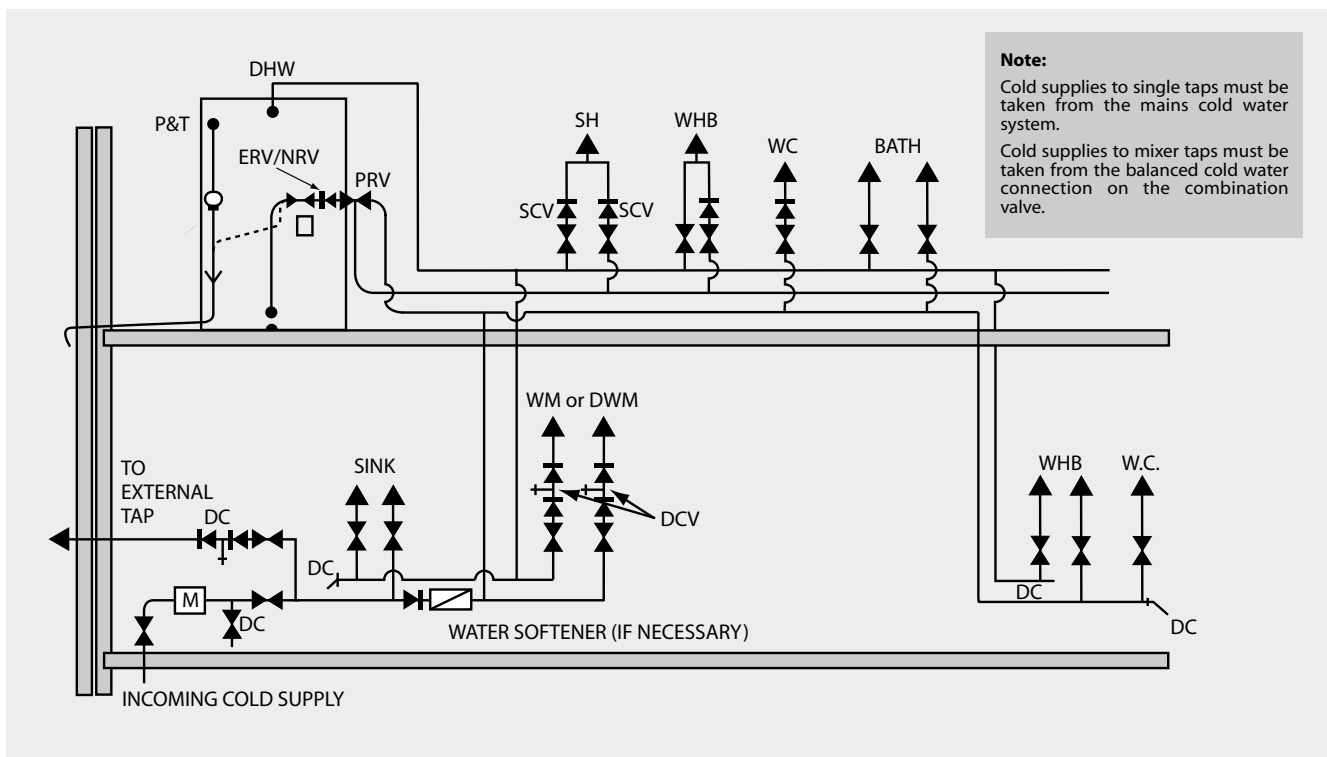

INSTALLATION

Typical Discharge Pipe Arrangement

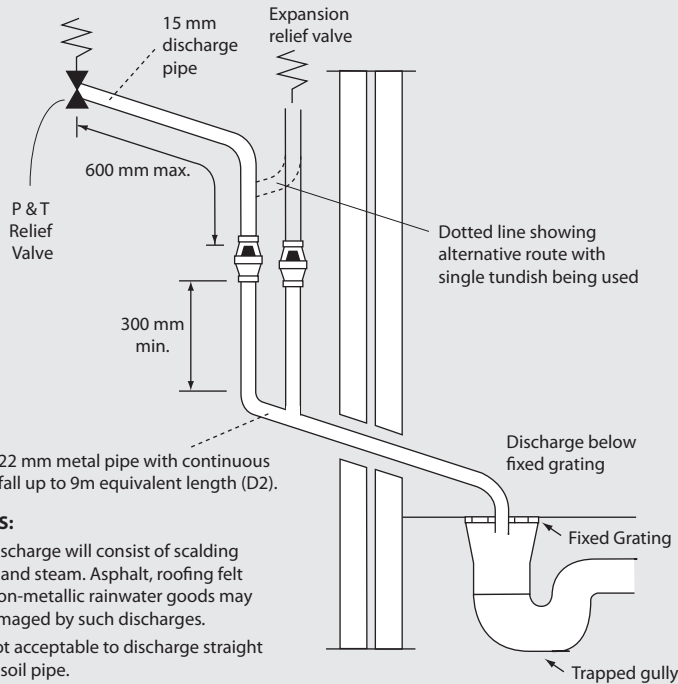

NOTES:

The discharge will consist of scalding water and steam. Asphalt, roofing felt and non-metallic rainwater goods may be damaged by such discharges. It is not acceptable to discharge straight into a soil pipe.

Pressure & Temperature/expansion Relief Valve Pipework

The relief valve should be installed to discharge in accordance with G3 of the Approved Document of the Building Regulations and should be piped to where it is visible, but will not cause danger to persons or damage to materials.

The following information is taken from Approved Document G3 of the Building Regulations and is provided to assist with the design and installation of the discharge pipework. However, the information is not exhaustive and reference should always be made to Approved Document G3 of the Building Regulations. The final decision regarding any arrangements rests with Building Control and it is recommended that their advice is sought if you have any concerns regarding this aspect of the installation.

The two safety valves will only discharge water under fault conditions. When operating normally water will not be discharged.

The tundish should be vertical, located in the same space as the unvented hot water storage system and be fitted as close as possible and within 600mm of the safety device e.g. the temperature relief valve.

The discharge pipe (D2) from the tundish should terminate in a safe place where there is no risk to persons in the vicinity of the discharge, be of metal and:

- a) Be at least one pipe size larger than the nominal outlet size of the safety device unless its total equivalent hydraulic resistance exceeds that of a straight pipe 9m long i.e. discharge pipes between 9m and 18m equivalent resistance length should be at least two sizes larger than the nominal outlet size of the safety device, between 18 and 27m at least 3 sizes larger, and so on. Bends must be taken into account in calculating the flow resistance. Refer to the table and the worked example.

An alternative approach for sizing discharge pipes would be to follow BS EN 806-2:2005 Specification for design installation, testing and maintenance of services supplying water for domestic use within buildings and their curtilages.

- b) Have a vertical section of pipe at least 300mm long, below the tundish before any elbows or bends in the pipe work.

- c) Be installed with a continuous fall.

Worked Example

The example below is for G1/2 temperature relief valve with a discharge pipe (D2) having 4 elbows and length of 7m from the tundish to the point of discharge.

From Table 1:

Maximum resistance allowed for a straight length of 22mm copper discharge pipe (D2) from a G1/2 temperature relief valve is: 9m subtract the resistance for 4 x 22mm elbows at 0.8m each = 3.2m.

Therefore the maximum permitted length equates to: 5.8m.

5.8m is less than the actual length of 7m therefore calculate the next largest size.

Maximum resistance allowed for a straight length of 28mm pipe (D2) from a G1/2 temperature relief valve equates to: 14m.

As the actual length is 7m, a 28mm (D2) copper pipe will be satisfactory.

Table 1: Sizing of copper discharge pipe 'D2' for a temperature relief valve with a G1/2 outlet size (as supplied)

Size of discharge pipework	Maximum length of straight pipe (no bends or elbows)	Deduct the figure below from the maximum length for each bend or elbow in the discharge pipe
22mm	Up to 9m	0.8m
28mm	Up to 18m	1m
35mm	Up to 27m	1.4m

INSTALLATION

d) It is preferable for the discharge to be visible at both the tundish and the final point of discharge but where this is not possible or practically difficult there should be clear visibility at one or other of these locations. Examples of acceptable discharge arrangements are:

1. Ideally below the fixed grating and above the water seal in a trapped gulley.
2. Downward discharges at a low level; i.e. up to 100mm above external surfaces such as car parks, hard standings, grassed areas etc are acceptable providing that where children play or otherwise come into contact with discharges, a wire cage or similar guard is positioned to prevent contact whilst maintaining visibility.
3. Discharges at a high level; e.g. into metal hopper and metal down pipe with the end of the discharge pipe clearly visible (tundish visible or not) or onto a roof capable of withstanding high temperature discharges of water and 3m from any plastic guttering systems that would collect such discharges.
4. Where a single common discharge pipe serves more than one system, it should be at least one pipe size larger than the largest individual discharge pipe (D2) to be connected.
5. If unvented hot water storage systems are installed where discharges from safety devices may not be apparent i.e. in dwellings occupied by blind, infirm or disabled people, consideration should be given to the installation of an electronically operated device to warn when discharge takes place.

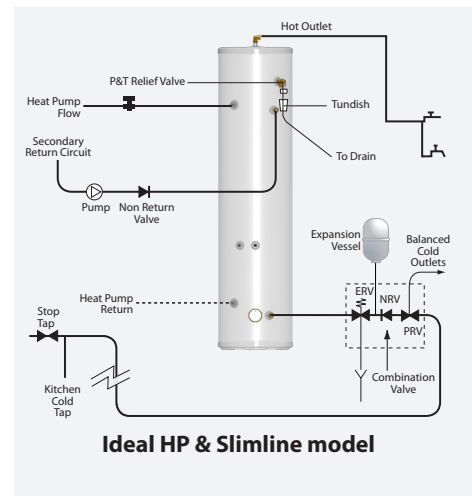

Safety

The safety devices supplied or fitted on an Ideal HP are selected for their suitability for the temperatures and pressures involved. They must not be changed, removed or by-passed and it is essential that only genuine replacement parts supplied or approved by Ideal Boilers are used. All parts are available to approved installers from Ideal Boilers.

Combination Inlet Group

Combines elements 1, 2 and 3 below.

1. *Pressure Reducing Valve* - The cold water supply to any mixer taps/showers must be taken from the cold water tapping of this valve to ensure balanced hot and cold pressures. This valve is factory set to ensure the correct operating pressure for the Ideal HP.
2. *Non Return Valve* - This is integral with the pressure reducing valve to prevent backflow of hot water towards cold water draw off points.
3. *Cold Water Expansion Relief Valve* - This safety device is preset at the factory and will relieve excess cold water pressure resulting from a fault condition.

Line Strainer

This is integral within the combination inlet group to reduce the likelihood of contaminants fouling the valve seat. Following installation this line strainer must be cleaned and replaced. This needs to be carried out on a regular basis, as part of the annual maintenance/service check.

Tundish

This is to allow the discharge from any Relief Valve to be seen. It must be fitted away from any electrical devices. See page 13 for discharge pipework details.

Expansion Vessels Installation

To prevent water stagnation and particulate accumulation affecting water quality, it is recommended that the expansion vessel be installed in the vertical orientation so that the fitting accommodating thermal expansion or a pressure surge is:-

1. bottom fed and upright; and
2. that the connecting pipework to the fitting:-
 - rises continuously; and
 - is kept to a minimum;

INSTALLATION

Temperature/pressure relief valve

This safety device is also pre-set at the factory and relieves before the temperature reaches 100°C. It is also a Pressure Relief Valve, and is pre-set to 6 bar.

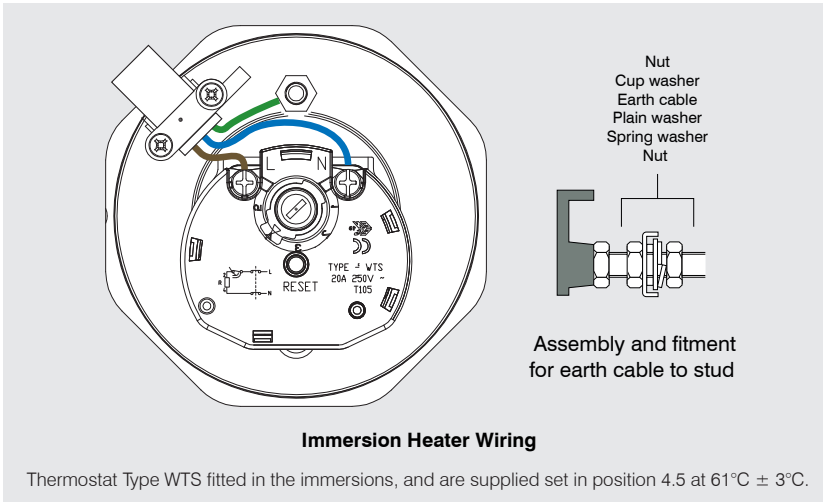

The immersion heater thermostats incorporate a manual reset safety/overheat cut out thermostat. Should this operate, investigate the cause before pressing the red reset button labelled safety. If there is no apparent fault adjust the control setting down slightly to prevent nuisance tripping.

If another heat source is used to heat the cylinder and this is allowed to raise the water temperature excessively then the overheat thermostat will trip.

All Ideal HP models are fitted with a 3kW immersion heater so that the store temperature can be raised above that which the heat pump provides, to boost the hot water performance if necessary and to protect against legionella eg. once a day or once a week.

The operation of the boost immersion heater can also be controlled by means of an independent time switch as shown schematically below. The 'ON' time settings on the immersion heater should be between 30 - 60 minutes later than the 'ON' times set for the hot water programmer channel.

Immersion Heater

The immersion heaters fitted to our units are 3kW 240V ~AC. Check that the mains supply conforms to this, and all external wiring conforms to the most recent revision of the IEE wiring regulations. An Incoloy element is used on this product for standard domestic use and water conditions, use our Titanium elements in all other circumstances, part number SH002.

The immersion heater is fitted into the hot water cylinder using an O-ring. After the unit is filled with water check for leaks to determine if the O-ring has sealed and tighten carefully using the appropriate tool. To prevent damage to the O ring do not use excessive force to tighten the immersion heater.

The immersion heater is supplied with a thermostat which has been tested for operation in the cylinder and complies with the European directives for Electromagnetic compatibility and radio interference. It is Rated at 20 Amp 250V ~AC.

The immersion thermostat has two terminals L and N. These should be connected as shown in the diagram. It has been our experience that crimp terminals make better connections. The immersion heater must be fully earthed (earth post) and connected via a double pole isolator switch.

For example if the hot water is programmed to come on between 0600 - 0900 and 1700 - 2200 then the immersion heater setting should be 0640 - 0900 and 1740 - 2200. This will give hot water heating by heat pump a priority.

Control/overheat Thermostat

Care must be taken to ensure that the probes are fully inserted into the pockets provided.

Danger of electrocution: before making any adjustments to the thermostat isolate the immersion heater from the mains electricity supply at the fuse spur unit.

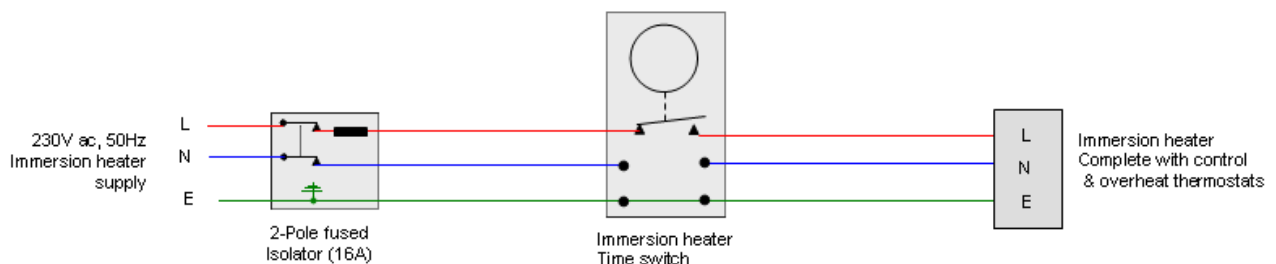

Typical schematic wiring diagram for the boost immersion heater using immersion programmable immersion heater timer.

INSTALLATION

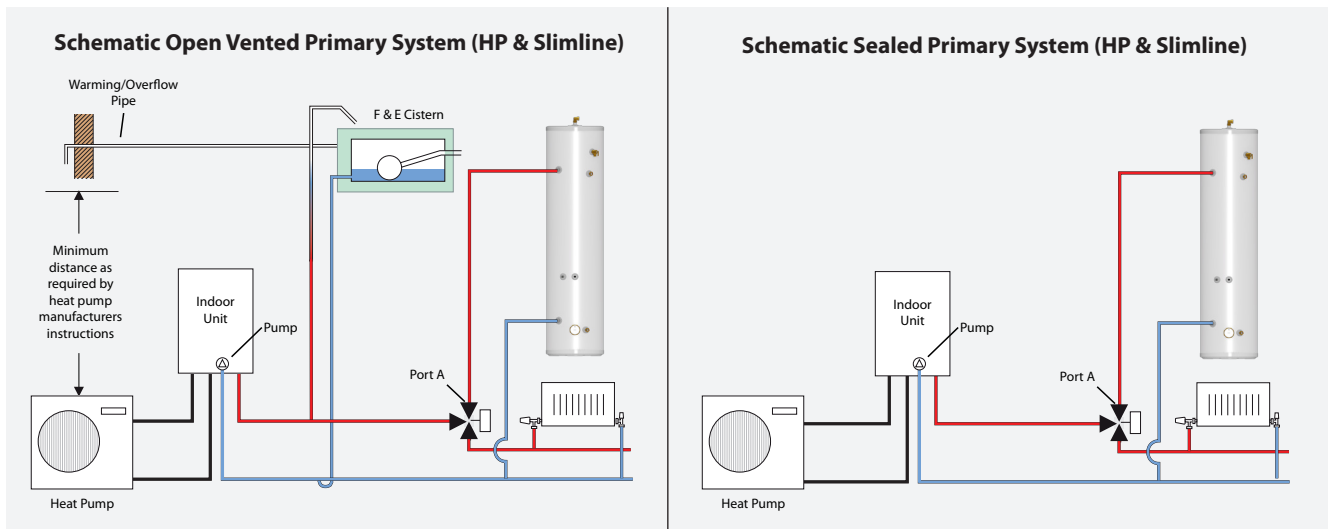

Heating And Primary Systems

Although the heat pump and the primary heating system should be sized and installed in accordance with BS EN 12828:2003, BS EN 12831:2003 & BS EN 14336:2004 the following should also be taken into account during the design and installation phase.

The heat pumps normally operate at lower flow temperatures; typically 45 – 55°C compared with 75 – 80°C for the boilers. Therefore if traditional radiators are used then, these should be oversized in accordance with the heat pump manufacturers recommendations.

For optimum efficiency (i.e. COP of a heat pump), low temperature under floor heating system should be considered.

The heat pumps normally operate at lower temperature difference between flow and return compared with the traditional boilers and therefore when sizing the pipework heat pump manufacturers recommendations should be taken into account.

Safety

Ideal HP is fitted with a combined temperature and pressure relief valve to cope with any increase in temperature and pressure in the cylinder above the design limits, when used with heat sources up to 45kW total output. This is the maximum heat input to the cylinder allowed by section G3 of the 'Approved Document G' of the Building Regulations.

The heat supply to the cylinder and hence the temperature of the stored water should be controlled as outlined below: -

- Heat supply from the primary heat source i.e. heat

The 3-port spring return motorised valve supplied should be fitted adjacent to the unit and controlled by the cylinder thermostat (combined control and overheat thermostat) supplied with the unit. The motorised valve and the thermostat must be wired so that the motorised valve switches off when either the control thermostat contact breaks when the set temperature is reached or the overheat thermostat contacts break when an overheat condition develops. The operation of the heat source should be controlled via the auxiliary switch of the motorised valve.

It is important to follow the wiring diagrams in the wiring section of these instructions.

- Sealed heating system

A heat pump selected must be suitable for use in a sealed heating system which may have working pressure of up to 3.0bar and it must be fitted with an overheat temperature cut-out device.

Unvented (i.e. sealed primary circuits may be filled or replenished by means of a temporary connection between the circuit and a water supply pipe provided a WRC 'Listed' double check valve and filling loop or some other no less effective backflow prevention device is permanently connected at the inlet to the circuit and the temporary connection is removed after use.

Alternatively, a CA device can be used which will allow the system to be permanently connected to the cold mains supply. The primary system can then be topped up, when required, in the same way as an open vented system fitted with an F&E cistern.

- Open vented heating system

It is essential that the primary circuit between the heat pump and the Ideal HP is pumped and that the cold feed and open vent connections are positioned to prevent pump over into the feed and expansion cistern and to ensure that the open vent is correctly sized. A typical arrangement of the open vented system is shown in diagram.

INSTALLATION

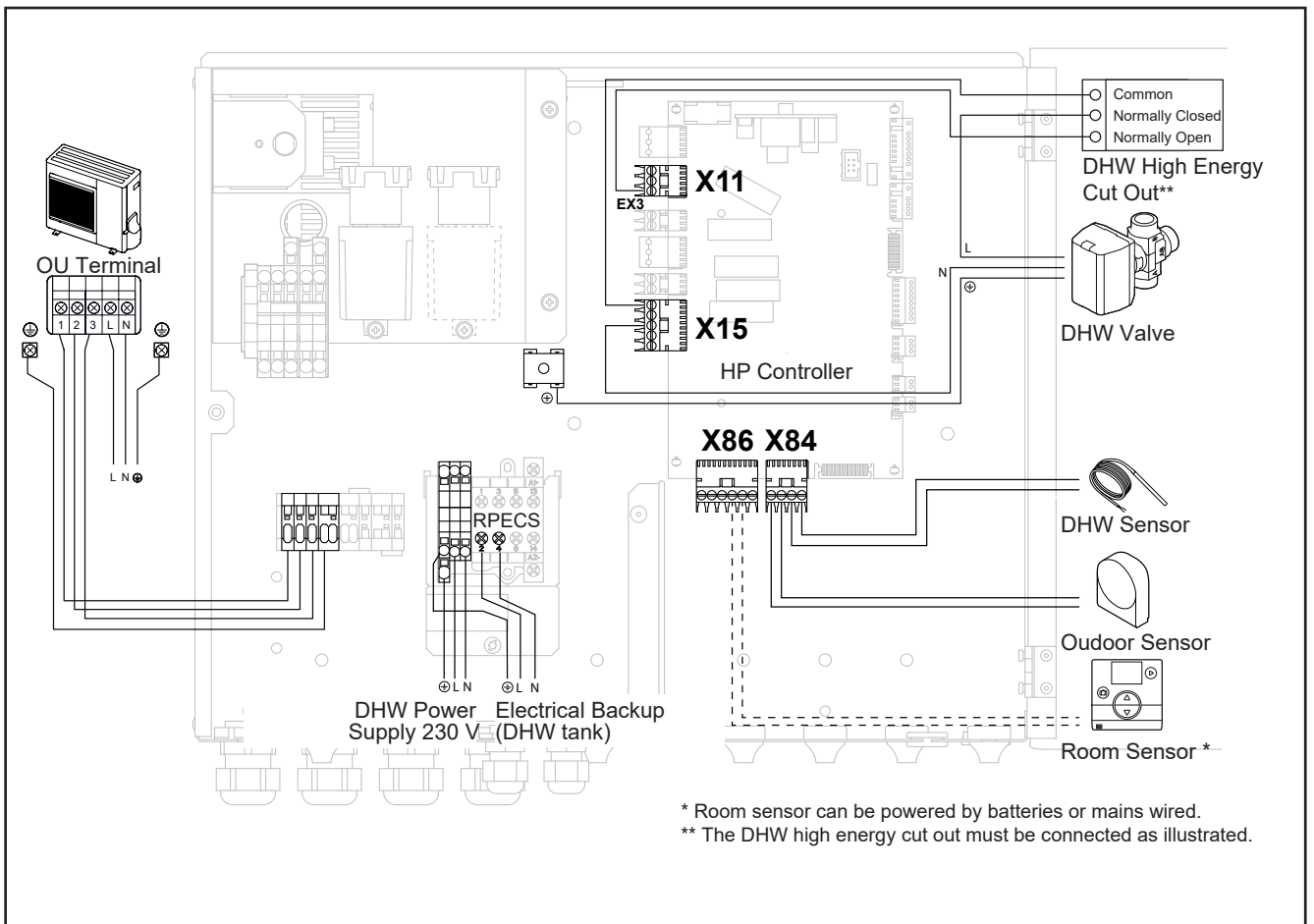
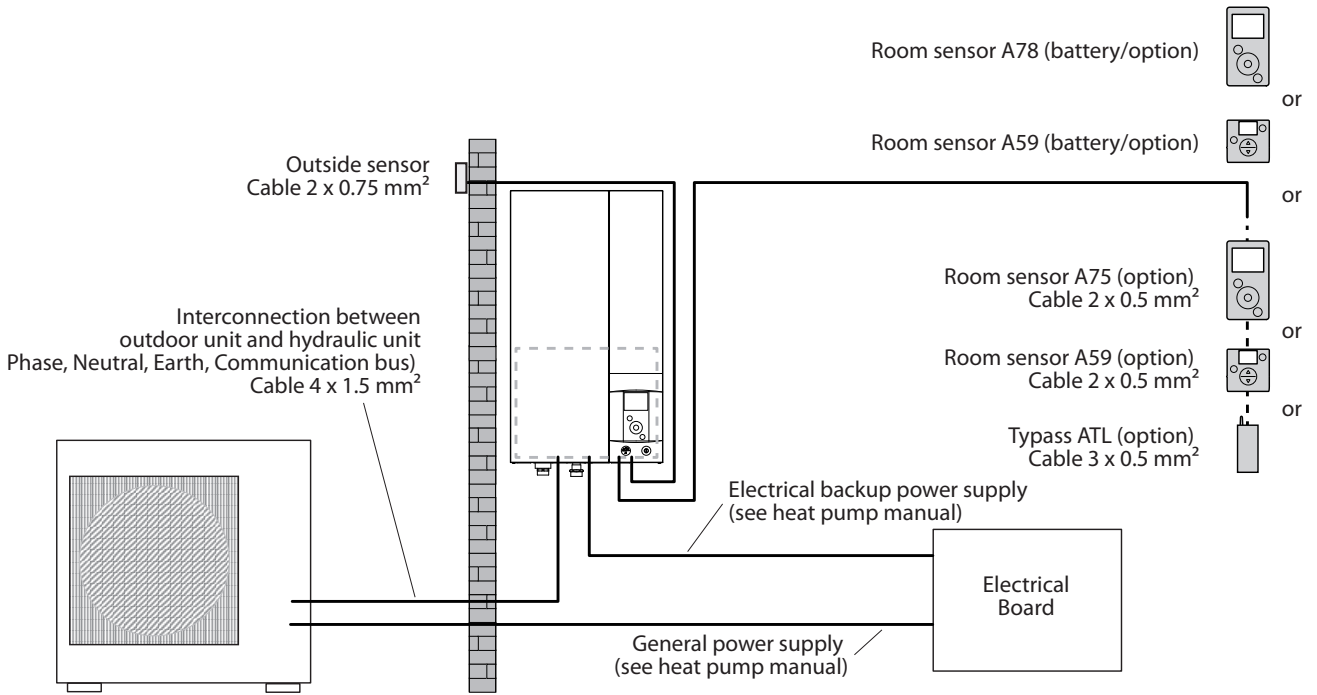

INSTALLATION

Connections can come loose in transit, and all should be checked before installation.

Ensure that the immersion heater achieves a temperature of at least 60°C in the store and that the wiring is in accordance with the diagram.

Check the pressure on the air side of the expansion vessel = 3 bar. This must be done when the water in the cylinder is free to expand in atmospheric pressure or the cylinder and relevant pipe work is empty.

Check that the drain cock is closed, and open all the cold and hot water taps and other terminal fittings. Allow the system to fill with water, and to run until there is no air left in the system. Close the taps and inspect the system closely for leaks.

Manually open the Relief Valves one by one and check that water is discharged and run freely through the tundish and out at the discharge point. The pipework should accept full bore discharge without overflowing at the tundish, and the valve should seat satisfactorily.

In line with good plumbing practice, use with excessive flux should be avoided. When soldering above the cylinder, ensure flux/solder does not contaminate the cylinder below, since this can cause corrosion, Flushing should be done performed as per BS EN 806:4 2010 section 6.2

Allow the cylinder to heat to normal working temperature, then thoroughly flush the domestic hot and cold water pipework through each tap.

NOTE: If this appliance is to be installed in other than a single domestic dwelling ie. in an apartment block or student flats etc., the hot and cold water system will need to be disinfected in accordance with BS EN 806:4 2010 section 6.3 and the Water Regulations.

Because the Ideal HP appliance is stainless steel, the use of chlorine as the disinfection agent can cause damage unless the appliance is adequately flushed and refilled with the mains water immediately on completion of the disinfection procedure. Damage caused through a failure to do this adequately will not be covered by the warranty.

For the above reasons we recommend the use of a non chlorine based disinfectant such as Fernox LP Sterox as manufactured by Cookson Electronics when carrying out disinfection of systems incorporating these appliances.

and open all hot taps until there is no air in the pipe work. **ENSURE CYLINDER IS DRAINED PRIOR TO CHECKING OR REMOVING FILTER FROM THE COMBINATION INLET GROUP.**

Allow the cylinder to heat to normal working temperature with whatever heat source is to be used, and check again for leaks. The Pressure Relief Valve should not operate during the heating cycle. If the P&T valve operates before the pressure relief valve due to high pressure, check that the inlet control group is fitted correctly, and no valve is between the inlet control group and the cylinder.

The heat pump/heating systems should be filled and commissioned in accordance with good practice following the guidance in BS 7593:2006/the heat pump manufacturers instructions. This includes adequately flushing the system to remove any debris that may have been introduced during installation/maintenance.

NOTE

At the time of commissioning, complete all relevant sections of the Benchmark Checklist located on the inside back pages of this document.

This must be completed during commissioning and left with the product to meet the Warranty conditions offered by Ideal Boilers.

IMPORTANT - DRAIN DOWN PROCEDURE

- 1 Switch off both the heat pump and the immersion heater
- 2 Open the nearest hot tap and run all hot water until cold
- 3 Close the incoming cold main at the stop tap
- 4 **Hold open the pressure and temperature relief valve until water stops discharging into the tundish**
- 5 Open all the taps in the property
- 6 Open the drain cock and immediately hold open the pressure and temperature relief valve again until the cylinder is empty

Remove the filter from the combination inlet group clean and replace. Refill the system

SERVICING AND MAINTENANCE

The Registered Installer is responsible for the safe installation and operation of the system. The installer must also make his customer aware that periodic maintenance of the equipment is essential for safety.

Maintenance periods will vary for many reasons. Ideal Boilers recommend a maximum of 12 months to coincide with heat pump maintenance. Experience of local water conditions may indicate that more frequent maintenance is desirable, eg, when water is particularly hard, scale-forming or where the water supply contains a high proportion of solids, eg, sand. Maintenance must include the following:

1. Check and clean filter
2. Manually check the operation of the temperature relief valve.
3. Manually check the operation of the expansion relief valve.
4. Check discharge pipes from temperature and expansion relief valves are free from obstruction and blockage and are not passing any water.
5. Check the condition and if necessary descale the heat exchangers in hard water areas.
6. Check that water pressure downstream of pressure reducing valve is within the manufacturers limits.
7. Check operation of motorised valve.
8. Check the pressure on the air side of the expansion vessel. This must be done with the pressure on the water side at zero (gauge pressure).
9. Check and advise the householder not to place any clothing or other combustible materials against or on top of this appliance.
10. On completion of the work, fill in the Benchmark Service Record at towards the back of this manual.

IMPORTANT NOTE

When draining down the appliance for any reason, the instructions provided in the Commissioning Section MUST be followed to prevent potential damage to the cylinder.

After servicing, complete the relevant Service Interval Record section of the Benchmark Checklist located on the inside back pages of this document.

SERVICING AND MAINTENANCE

Scale

In hard water areas it is recommended that an in-line scale inhibitor is fitted. Reducing the temperature of the stored water will reduce the rate at which scale forms. If the recovery rate is badly affected, this is an indication that scaling may have occurred. In this event, follow the procedures as recommended by a reputable Water Treatment Company.

General

No water at the tap. Check that the mains water supply is turned ON. Check the line strainer is not blocked. Check that the combination valve has been fitted so that water is flowing in the correct direction.

If the water at the tap is cold, ensure that the boiler has been switched ON and is working correctly. Check that there are no air locks in the primary system. ISOLATE THE UNIT AT THE MAINS ELECTRIC SUPPLY AND THEN CHECK THE FOLLOWING:

- i. The cylinder thermostat
- ii. The thermal cut-out, which can be re-set by pushing the red button
- iii. The motorised valve
- iv. The boiler thermostat
- v. The boiler thermostat cut-out (if fitted)

ANY ENERGY CUT-OUT MUST NEVER BE BY-PASSED UNDER ANY CIRCUMSTANCES.

If the units are not getting hot and the heat source is electrical, ensure that the immersion heaters are isolated from the mains before re-setting the energy cut-out. If the immersion heater(s) need replacing this should be done with the units supplied from Ideal Boilers.

Discharge From Relief Valves

If cold water is discharging from the expansion relief valve into the tundish check the pressure on the expansion vessel when cold and recharge if necessary.

If the fault continues and the problem cannot be stopped by operating the easing control a few times then either the Pressure Reducing Valve or the Relief Valve may be at fault. If the cold water pressure is too high, this would suggest that the Pressure Reducing Valve is at fault and the Ideal approved replacement should be fitted. If the pressure is correct then the Relief Valve will require replacing with a Ideal approved component.

See Commissioning for drain down procedure.

If there is an overheat fault and very hot water is being discharged, turn off the heat source, **but not the water supply.**

When the supply is cool, check thermostats and energy cut-outs in the heat pump and immersion heaters and replace the faulty component with one supplied by Ideal and check that it works correctly before returning the system to full operation.

SERVICING AND MAINTENANCE

FAULT - No Hot Water

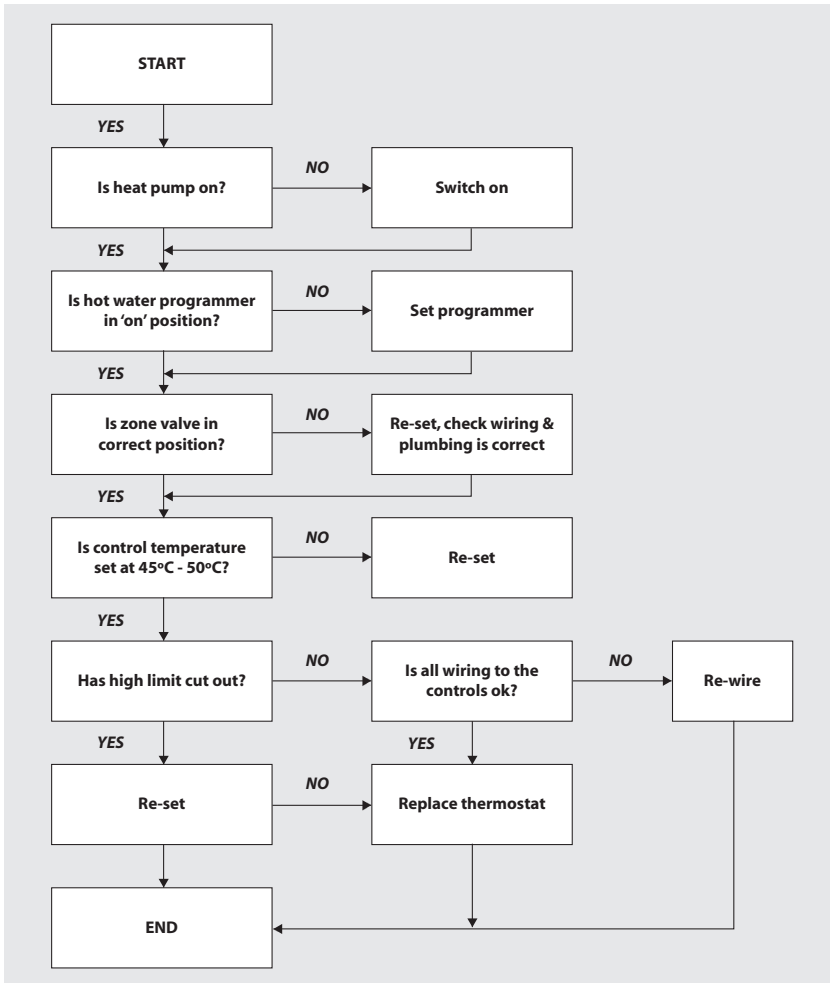

FAULT - Poor Water Flow at Hot Taps

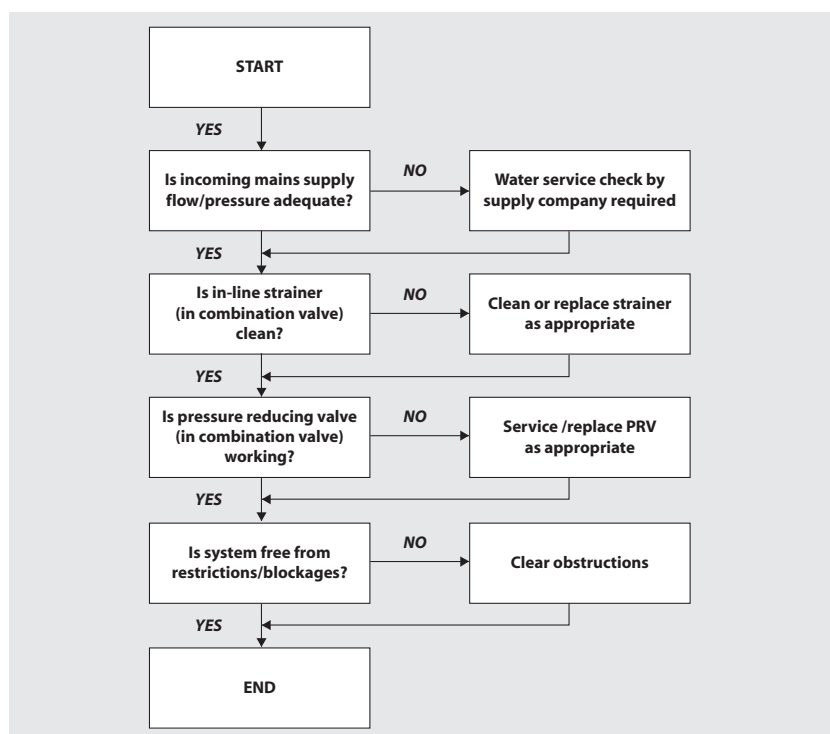

SERVICING AND MAINTENANCE

FAULT - Water Discharge Into Tundish

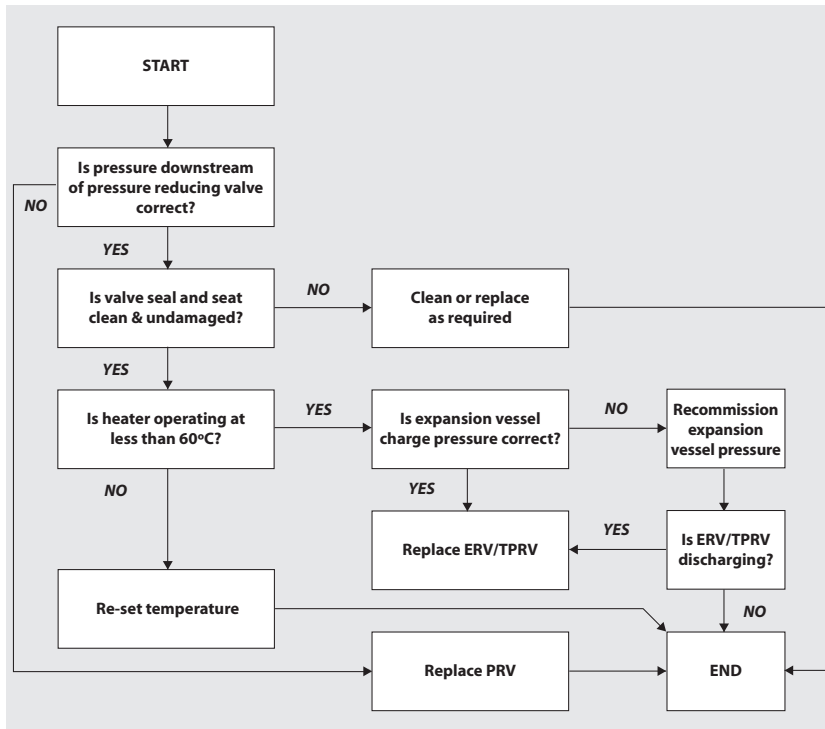

SERVICING AND MAINTENANCE

SPARE PARTS LIST			
	Description	Quantity	Stock Code No.
1	3kW immersion element	1	176749
2	22mm 90° compression elbow c/w/drain	1	180996
3	Lift up pressure and temperature relief valve 6 bar 95°C	1	180999
4	Inlet group set at 3 bar c/w expansion relief valve set at 4.5 bar	1	176750
5	18 litre expansion vessel	1	176752
6	24 litre expansion vessel	1	176753
7	35 litre expansion vessel	1	176754
8	Overheat manual reset thermostat	1	181001
9	15mm x 22mm tundish	1	176759
10	28mm 3 port valve	1	181002

APPENDIX

Water Savings

Water Related Costs Can Be Reduced By Good Plumbing Practice

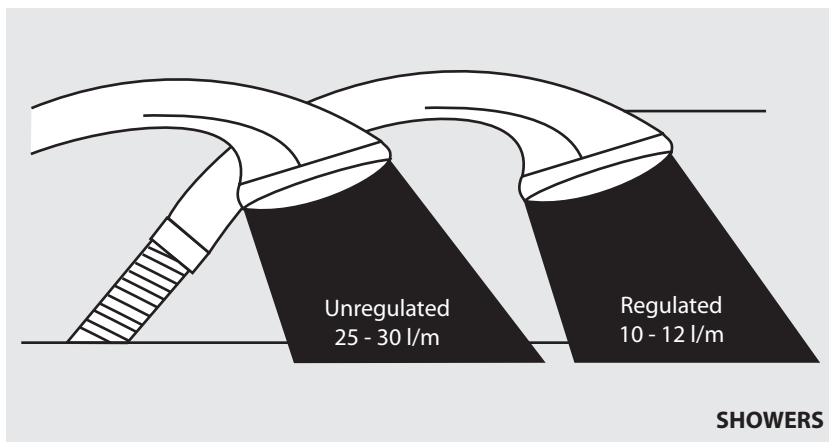
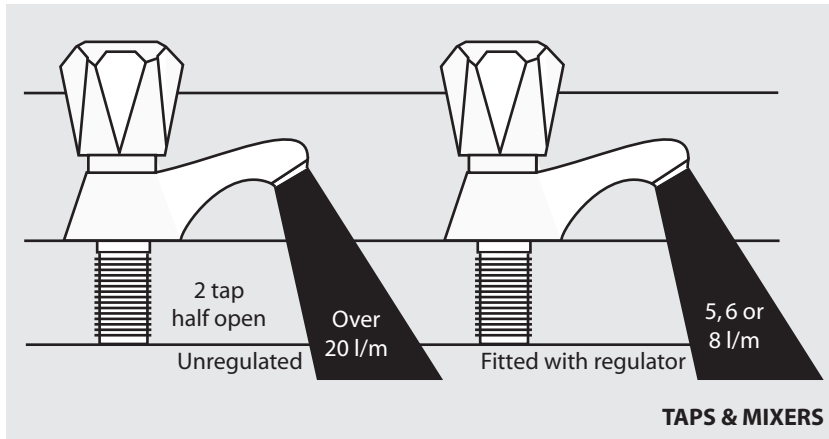

Vast quantities of water are needlessly run off to waste due to Taps, Mixers and Showers discharging flow rates far in excess of the rates required for them to perform their duties.

The contrasting flow rates shown on this leaflet clearly illustrate the savings that can be made whilst still providing a good performance.

British made Aquaflow Regulators provide constant flow rates by automatically compensating for supply pressure changes between 1 bar & 10 bars.

To facilitate installation into the wide range of plumbing equipment which is encountered in the U.K, Four Fixing Options are available:-

Options For Showers

1. MXF "DW" Range - For fitting behind Fixed Shower Heads or onto Flexible Hoses for Handshowers (preferably onto the inlet end when lightweight hoses are used).
2. Compression Fitting Range. "In Line" regulators as in Option 4 for Taps & Mixers.

Information by courtesy of

AQUAFLOW REGULATORS LTD

Haywood House, 40 New Road, Stourbridge, West Midlands DY8 1PA
TELEPHONE (01384) 442611 FAX: (01384) 442612

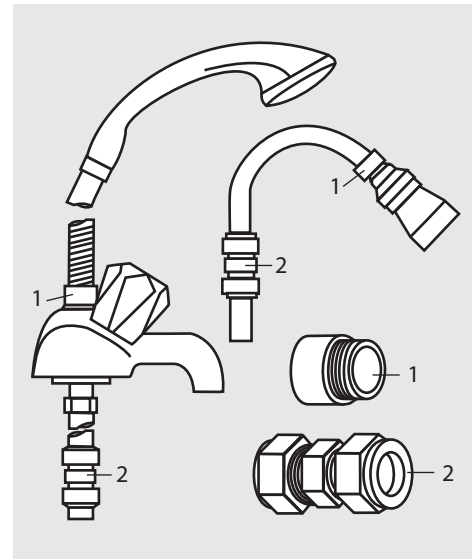

4 Fixing Options For Taps & Mixers

1. MK Range - Combined Regulators & Aerator for screwing onto Taps & Mixers with internal or external threads on their noses. Anti Vandal models also available.
2. MR05-T Range - Internal Regulators. Push-fit into Tap or Mixer seats. Produced in three sizes - 12.5mm (BS1010), 12mm & 10mm, Flangeless models also available for Taps with Low Lift washers.
3. MXF Standard Range - Screw on tail models for Taps & Mixers. Fix onto the tails before fitting the tap connectors. Available in 3/8", 1/2", 3/4" and 1" BSP.
4. Compression Fitting Range - "In Line" regulators housed in 15mm & 22mm CXC Couplers & Isolating Valves. "UKWFB" listed by the Water Research Centre. Isolation valves available for slotted screwdriver operation or with coloured plastic handles. Now available also in plastic bodied push-fit couplers & valves.

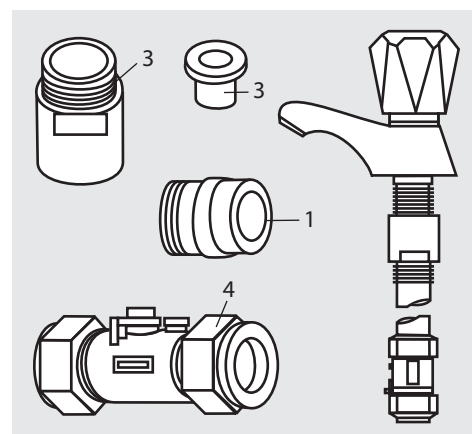

APPENDIX

MANUAL HANDLING OF APPLIANCE PRODUCTS

Description

Manual handling means any transporting or supporting of a load (including lifting, putting down, pushing, pulling, carrying or moving) by hand or bodily force.

Scope

This assessment will cover the largest unit within each product range.

For specific weights and dimensions please refer to technical data section.

Main Hazards

Vision may not be clear due to the size of the products.
Adopting an incorrect method of lifting may cause injury, attempting to lift these products will require help from others. (Team lifts)

Control Measures

Manual lifting procedure

The lift, key factors in safe lifting are:

- a. **Balance**
 - b. **Position of back**
 - c. **Positioning of the arms and body**
 - d. **The hold**
 - e. **Taking the lead for team lifts**
-
- a. **Balance** - Since balance depends essentially upon the position of the feet, they should be apart about hip breadth with one foot advanced giving full balance sideways and forward without tension. In taking up this position, lifting is done by bending at the knees instead of the hips and the muscles that are brought into use are those of the thigh and not the back.
 - b. **Position of back** - Straight - not necessary vertical. The spine must be kept rigid, this coupled with a bent knee position, allows the centre line of gravity of the body to be over the weight so reducing strain.
 - c. **Positioning of arms and body** - The further arms are away from the side, the greater the strain on the shoulders, chest and back. Keep elbows close to the body arms should be straight.
 - d. **The hold** - Before lifting ensure you have a good hold.

- e. **Taking the lead for team lifts**- As more than one person is required for these products ensure that one person is taking the lead. **This may be you** so ensure that each person that is helping is made aware of the weight and of the items listed within this assessment. Make sure you and any others helping know the route you intend to take that it is clear of any obstructions. Never jerk the load as this will add a little extra force and can cause severe strain to the arms, back and shoulders. If there are steps involved decide on where you will stop and take a rest period. Move smoothly and in unison taking care to look and listen to others helping with the lift. Where possible use a sack truck to move the product over long flat distances, only lift the products when necessary. If in doubt stop and get more help.

Individual capability

Individual capability plays an important part in handling these products. Persons above average build and strength will find it easier and should be in good health. Persons below average build and strength may require more rest periods during the handling process.

Pregnant women should not carry out this operation.

Persons who are not in good health should seek medical advice prior to commencing any lifting or manual handling operation.

Residual risk

Following the guidelines given above will reduce any risk to injury.

All persons carrying out this operation must be fully trained and copies of the specific risk assessment made available for inspection and use in their training process.

Further guidance on Manual Handling can be obtained from the Health and Safety Executive. Manual Handling Operations Regulations 1992 (amended by Health and Safety (Miscellaneous Amendments) Regulations 2002.

TERMS AND CONDITIONS

Ideal Unvented Cylinder Warranty Terms and Conditions

Ideal Boilers Limited provides a 2 year parts and labour warranty on the cylinder solution provided, the inner cylinder skin is further covered for on a replacement basis beyond this period to 25 years from the date of purchase, subject to adherence with the following terms and conditions of warranty

1. The unit has been installed and commissioned in accordance with our installation and service instructions and all relevant codes of practice and regulations in force at the time of installation.
2. All necessary inlet controls and safety valves have been fitted correctly.
3. The unit has only been used for the storage of potable water supplied from the public mains. The water quality shall be in accordance with
4. European Council Directive 98/83 EC, or revised version at the date of installation, and is not fed with water from a private supply. Particular:
Chloride content: Max. 200 mg/l
Sulphate content: Max. 200 mg/l
Combination chloride/sulphate: Max. 300 mg/l (in total)
5. If the newly fitted water heater is not in regular use then it must be flushed through with fresh water for at least 15 minutes. Open at least one hot water tap once per week, during a period of at least 4 weeks.
6. The Cylinder is registered within 30 days of installation, this can be done by calling Ideal Boilers on **01482 498660**
7. The unit has been regularly maintained as detailed in the installation and service instructions
8. If the Cylinder suffers a mechanical breakdown, calls must be raised with Ideal Boilers Customer Services on **01482 498660**
Our normal working times, excluding Bank Holidays are:
8am – 6pm Monday to Friday, 8am – 4pm Saturday,
8.00am – 12 noon Sunday
9. The guarantee for the stainless steel vessel is for twenty five years against material defect or manufacturing faults if the original unit is returned to us AND PROVIDED THAT:
 - (i) It has not been modified, other than by Ideal.
 - (ii) It has not been subjected to wrong or improper use or left uncared for.
 - (iii) It has only been used for the storage of potable water supplied from the public mains, max 200mg/litre chloride.
 - (iv) It has not been subjected to frost damage.
 - (v) The benchmark service record is completed after each annual service.
 - (vi) The unit has been serviced annually
10. If the stainless steel vessel proves to be defective either in materials or workmanship we reserve the right to either repair or supply replacements or the closest possible substitute in the case of any obsolete product and will collect and deliver to any address in England, Scotland and Wales (excluding all islands):
Our normal working times, excluding Bank Holidays are:
8am – 6pm Monday to Friday, 8am – 4pm Saturday,
8.00am – 12 noon Sunday
Please note:
 - a. Engineers will only attend to Ideal products where it is considered by the engineer that the installation does not pose a risk to health and safety.
 - b. A permanently fixed access ladder must service installations in lofts or attics. Adequate lighting and permanently fixed flooring must also be available.
 - c. Compartment installations must provide minimum working clearances as detailed in the installation instructions. Ideal will not accept responsibility for the removal of fixtures or fittings in order to gain access for repairs.
11. The guarantee does not apply:
 - a. If the Cylinder is removed from its place of installation without our prior consent.
 - b. To any defect, damage or breakdown caused by inadequate servicing of the cylinder or by deliberate action, accident, misuse or third party interference including modification or an attempted repair which does not fully comply with industry standards.
 - c. To any defect, damage or breakdown caused by the design, installation and maintenance of the central heating system.
 - d. To de-scaling or other work required as a result of hard water scale deposits or from damage caused by aggressive water or sludge resulting from corrosion.
 - e. If the claim/contact procedure set out in section 12 is not adhered to
 - f. To any other costs or expenses caused by or arising as a result of the breakdown of an Ideal Cylinder.
 - g. To any defect resulting from the incorrect installation of the cylinder.
 - h. To any costs incurred during delays in fixing reported faults.
12. We reserve the right to charge a call-out fee where:
 - a. A fault cannot be found.
 - b. The breakdown or fault has been caused by an event, which is excluded from the guarantee – refer to section 11
 - c. Failure to cancel an agreed appointment prior to our engineers visit
 - d. The Cylinder is outside the period of guarantee or the conditions of the guarantee have not been met.
13. If we fit replacement parts or replace a cylinder it will not extend the period of the warranty. All replaced parts or cylinders will become the property of Ideal Boilers Ltd.
14. The warranty applies only where an Ideal cylinder has been installed in a domestic dwelling in mainland United Kingdom, Northern Ireland and I.O.W. to provide hot water.

Our Ideal Warranty is offered in addition to the rights provided to a consumer by law. Details of these rights can be obtained from a Trading Standards Authority or a Citizen Advice Bureau. Guarantor – Ideal Boilers Ltd, P.O. Box 103, National Avenue, Hull, HU5 4JN.

MAINS PRESSURE HOT WATER STORAGE SYSTEM COMMISSIONING CHECKLIST

This Commissioning Checklist is to be completed in full by the competent person who commissioned the storage system as a means of demonstrating compliance with the appropriate Building Regulations and then handed to the customer to keep for future reference.

Failure to install and commission this equipment to the manufacturer's instructions may invalidate the warranty but does not affect statutory rights.

Customer name:										Telephone number:														
Address:																								
Cylinder Make and Model																								
Cylinder Serial Number																								
Commissioned by (PRINT NAME):										Registered Operative ID Number														
Company name:										Telephone number:														
Company address:																								
										Commissioning date:														
To be completed by the customer on receipt of a Building Regulations Compliance Certificate*:																								
Building Regulations Notification Number (if applicable)																								
ALL SYSTEMS PRIMARY SETTINGS (indirect heating only)																								
Is the primary circuit a sealed or open vented system?										Sealed					Open									
What is the maximum primary flow temperature?															°C									
ALL SYSTEMS																								
What is the incoming static cold water pressure at the inlet to the system?															bar									
Has a strainer been cleaned of installation debris (if fitted)?										Yes					No									
Is the installation in a hard water area (above 200ppm)?										Yes					No									
If yes, has a water scale reducer been fitted?										Yes					No									
What type of scale reducer has been fitted?																								
What is the hot water thermostat set temperature?															°C									
What is the maximum hot water flow rate at set thermostat temperature (measured at high flow outlet)?															l/min									
Time and temperature controls have been fitted in compliance with Part L of the Building Regulations?															Yes									
Type of control system (if applicable)										Y Plan					S Plan					Other				
Is the cylinder solar (or other renewable) compatible?										Yes					No									
What is the hot water temperature at the nearest outlet?															°C									
All appropriate pipes have been insulated up to 1 metre or the point where they become concealed															Yes									
UNVENTED SYSTEMS ONLY																								
Where is the pressure reducing valve situated (if fitted)?																								
What is the pressure reducing valve setting?															bar									
Has a combined temperature and pressure relief valve and expansion valve been fitted and discharge tested?										Yes					No									
The tundish and discharge pipework have been connected and terminated to Part G of the Building Regulations															Yes									
Are all energy sources fitted with a cut out device?										Yes					No									
Has the expansion vessel or internal air space been checked?										Yes					No									
THERMAL STORES ONLY																								
What store temperature is achievable?															°C									
What is the maximum hot water temperature?															°C									
ALL INSTALLATIONS																								
The hot water system complies with the appropriate Building Regulations															Yes									
The system has been installed and commissioned in accordance with the manufacturer's instructions															Yes									
The system controls have been demonstrated to and understood by the customer															Yes									
The manufacturer's literature, including Benchmark Checklist and Service Record, has been explained and left with the customer															Yes									
Commissioning Engineer's Signature																								
Customer's Signature																								
(To confirm satisfactory demonstration and receipt of manufacturer's literature)																								

*All installations in England and Wales must be notified to Local Authority Building Control (LABC) either directly or through a Competent Persons Scheme. A Building Regulations Compliance Certificate will then be issued to the customer.



While this Checklist can be used for any installation covered by its description, only appliances manufactured by Scheme Members will be covered by the rules and requirements of the Benchmark Scheme.

SERVICE RECORD

It is recommended that your hot water system is serviced regularly and that the appropriate Service Record is completed.

Service Provider

Before completing the appropriate Service Record below, please ensure you have carried out the service as described in the manufacturer's instructions.

SERVICE 01		Date:	SERVICE 02		Date:
Engineer name:		Engineer name:		Engineer name:	
Company name:		Company name:		Company name:	
Telephone No:		Telephone No:		Telephone No:	
Comments:		Comments:		Comments:	
.....		
.....		
.....		
Signature		Signature		Signature	
SERVICE 03		Date:	SERVICE 04		Date:
Engineer name:		Engineer name:		Engineer name:	
Company name:		Company name:		Company name:	
Telephone No:		Telephone No:		Telephone No:	
Comments:		Comments:		Comments:	
.....		
.....		
.....		
Signature		Signature		Signature	
SERVICE 05		Date:	SERVICE 06		Date:
Engineer name:		Engineer name:		Engineer name:	
Company name:		Company name:		Company name:	
Telephone No:		Telephone No:		Telephone No:	
Comments:		Comments:		Comments:	
.....		
.....		
.....		
Signature		Signature		Signature	
SERVICE 07		Date:	SERVICE 08		Date:
Engineer name:		Engineer name:		Engineer name:	
Company name:		Company name:		Company name:	
Telephone No:		Telephone No:		Telephone No:	
Comments:		Comments:		Comments:	
.....		
.....		
.....		
Signature		Signature		Signature	
SERVICE 09		Date:	SERVICE 10		Date:
Engineer name:		Engineer name:		Engineer name:	
Company name:		Company name:		Company name:	
Telephone No:		Telephone No:		Telephone No:	
Comments:		Comments:		Comments:	
.....		
.....		
.....		
Signature		Signature		Signature	



*The code of practice for the installation,
commissioning & servicing of central heating systems*



FM 02057

TECHNICAL TRAINING

The Ideal Technical Training Centre offers a series of first class training courses for domestic, commercial and industrial heating installers, engineers and system specifiers.

For details of courses please ring:..... 01482 498432

Ideal Boilers Ltd. pursues a policy of continuing improvement in the design and performance of its products.

The right is therefore reserved to vary specification without notice.

Ideal Boilers Ltd., PO Box 103, National Avenue, Kingston Upon Hull, HU5 4JN

Tel 01482 492251 Fax 01482 448858

Registration No. London 322 137

Ideal Technical Helpline: 01482 498663
Ideal Consumer Helpline: 01482 498660
Ideal Cylinder Registration: 01482 498660
www.idealboilers.com



Your ideal HP unvented cylinder is automatic in normal use, but requires routine maintenance which is normally carried out at least annually along with the boiler service. The maintenance must be carried out by a suitably competent tradesperson who is qualified to work on unvented cylinders. The checks/work needed are listed in the maintenance part of these instructions.

The control thermostat for indirect heat exchanger heat up of our cylinders are usually set at between 60°C - 65°C. During commissioning the actual temperature that the cylinder reaches when the thermostat(s) operate should be tested and adjusted so that it achieves a minimum of 60°C, in order to comply with the Legionella pasteurisation requirements.

When initially opening the taps, a small surge in flow may be experienced, which disappears as the pressure in the system stabilises. This is quite normal with these types of systems and does not indicate a fault.

In some areas the water will initially appear cloudy, but will quickly clear when left to stand. This is nothing to be concerned about and is due to aeration of the water.

WARNING - If water is seen flowing through the tundish, this indicates a fault condition which needs action.

If the discharge is hot and continuous, turn the boiler and/or the immersion heaters off, but do not turn off the cold water to the appliance until the discharge is cold. **Note:** The discharge may stop by itself as the discharge cools.

If the discharge is cold and intermittent, no immediate action is needed but this indicates a problem with the expansion vessel.

However, in both cases you must call the registered installer / a suitably qualified, competent tradesperson, advise them that you have an unvented cylinder and request a maintenance visit.

DO NOT, at any time, tamper in any way with the safety valves or overheating thermostats/wiring.



HEAT PUMP CYLINDER



When replacing any part on this appliance, use only spare parts that you can be assured conform to the safety and performance specification that we require. Do not use reconditioned or copy parts that have not been clearly authorised by Ideal Boilers. For the very latest copy of literature for specification and maintenance practices visit our website www.idealboilers.com where you can download the relevant information in PDF format.

USER GUIDE

HEAT PUMP CYLINDER

