

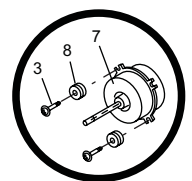

DHW expansion kit code 075118

For heat pump,
split 2 services

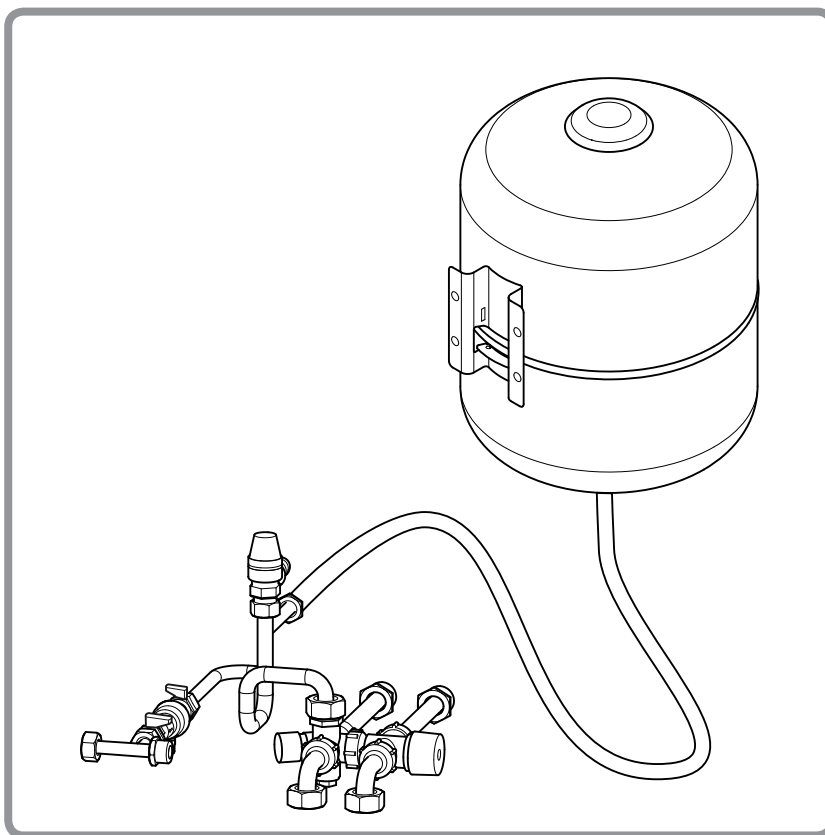

Installation instructions

**intended for the
professional technician**

these must be kept safe
for subsequent consultation

Contents

Description of the equipment	3
Installation instructions	3
Mounting and installation	3
Instructions for user	6
Filling the installation	6
Adding water of the hydraulic circuit.	6
Closing the cold water supply	6
Spare parts	7

1 Description of the equipment

The DHW expansion kit fits into the hydraulic unit of heat pumps :

- alfea extensa duo A.I.
- alfea excellia duo A.I.
- alfea extensa duo +.
- alfea excellia duo.

The DHW expansion kit consists of security organs and comfort :

- Backflow preventer (Filling, Protection against backflow phenomena).
- Safety valve (Protection of the DHW tank).
- Thermostatic mixer valve (Setting and limitation of the temperature of hot water (DHW) distribution).
- DHW expansion vessel (Protection of the safety valve, Water saving).

2 Installation instructions

2.1 Mounting and installation

Figure 1 :

- Move the expansion vessel.
- Disconnect the hose from the expansion vessel (**A**).
- Clean the thread of the male connector.
- Delete the DHW pipes.

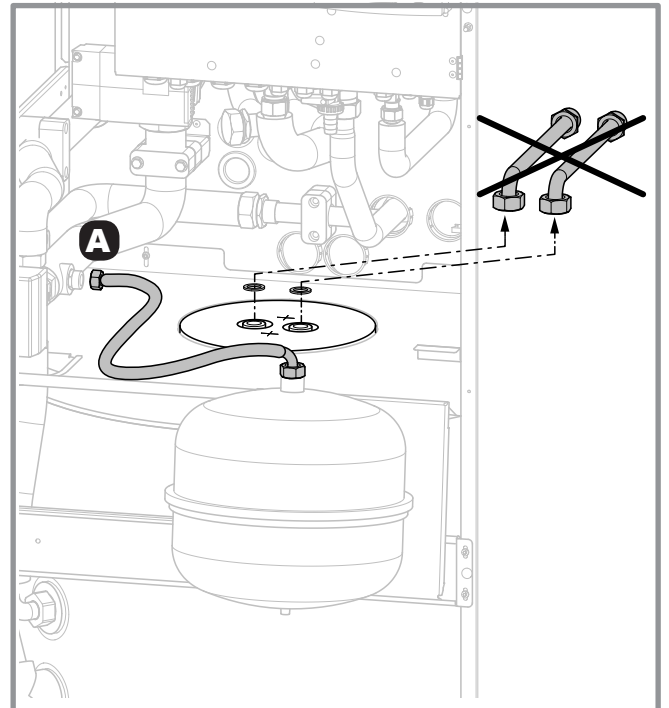

figure 1 -

Figure 2 :

- Fix the bracket (**B**) on the rear panel (4 screws) or on the wall near the appliance.
- Connect sealed the expansion vessel and the flexible hose (**C**).
- Fix the expansion vessel on the bracket.

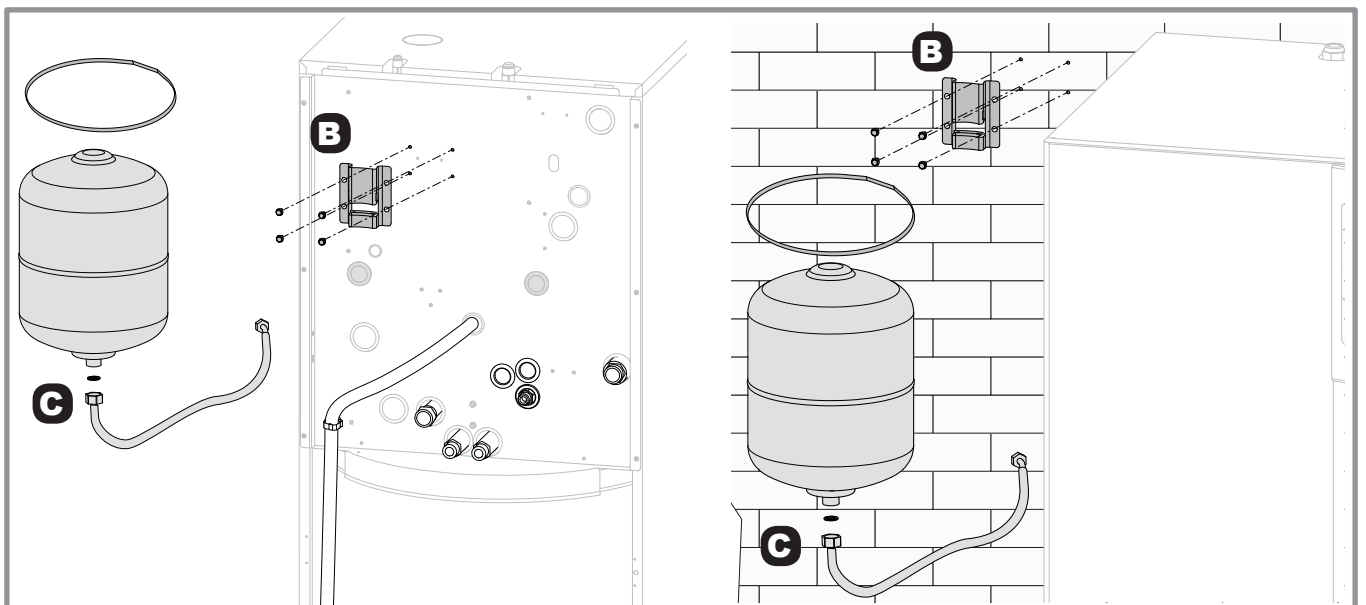

figure 2 - Mounting of DHW expansion vessel

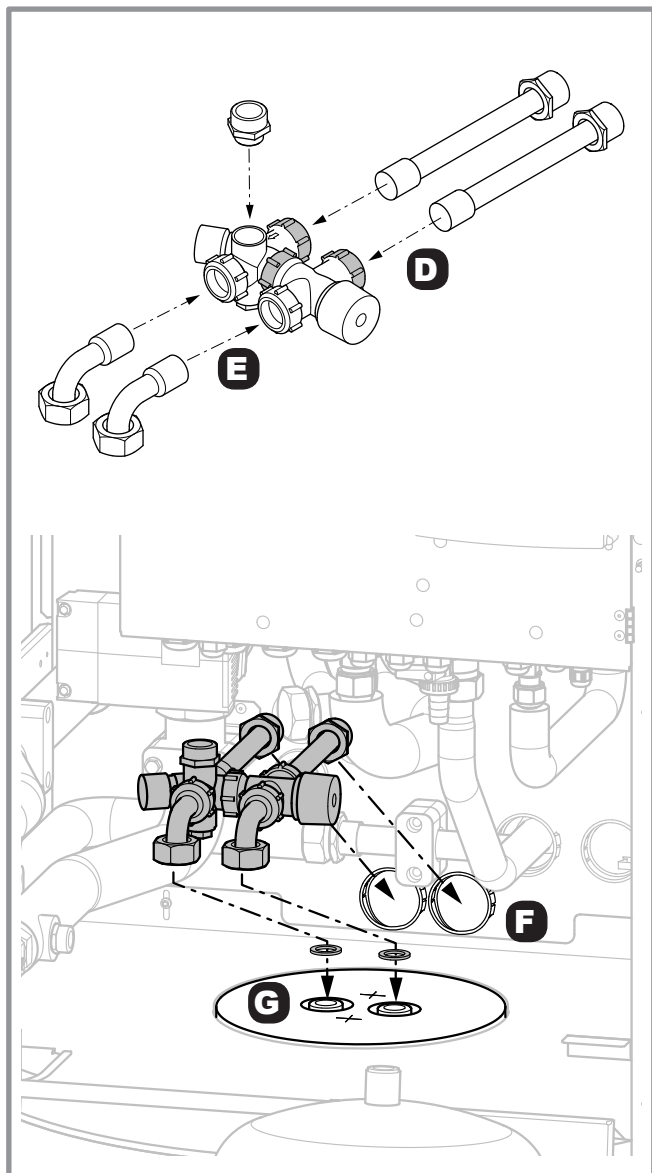

figure 3 - Mounting mixer

Figure 3 :

- Assemble the parts of the mixer set respecting the mounting direction.
- To facilitate mounting of connection with clamping ring, coat the thread and bevel with lubricant.
- Hard tighten the 3 nuts (D) of mixer set / DHW output pipes with a key 32.
 - ☞ **Do not tighten the nuts (E) now.**
- Insert the kit pipes in the rear cover (F).
- Fit the mixer set using the supplied gaskets (G).
 - ☞ **Tighten the nuts (E).**

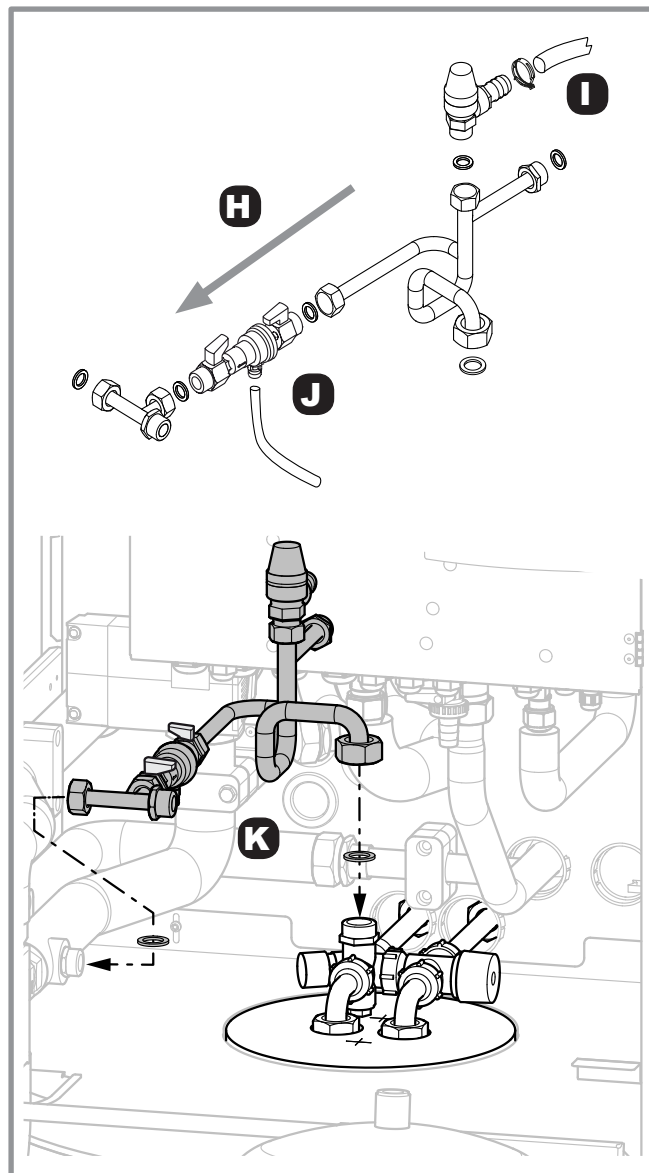

figure 4 - Mounting of backflow preventer

Figure 4 :

- Assemble the parts of the whole backflow preventer and safety valve respecting the mounting direction (H).
- Fix the flexible hose Ø 16 on the evacuation of the safety valve with clamp (I).
- Fix the flexible hose Ø 10 on the evacuation of the backflow preventer (J).
- Mount the the whole backflow preventer and safety valve using the supplied gaskets (K).

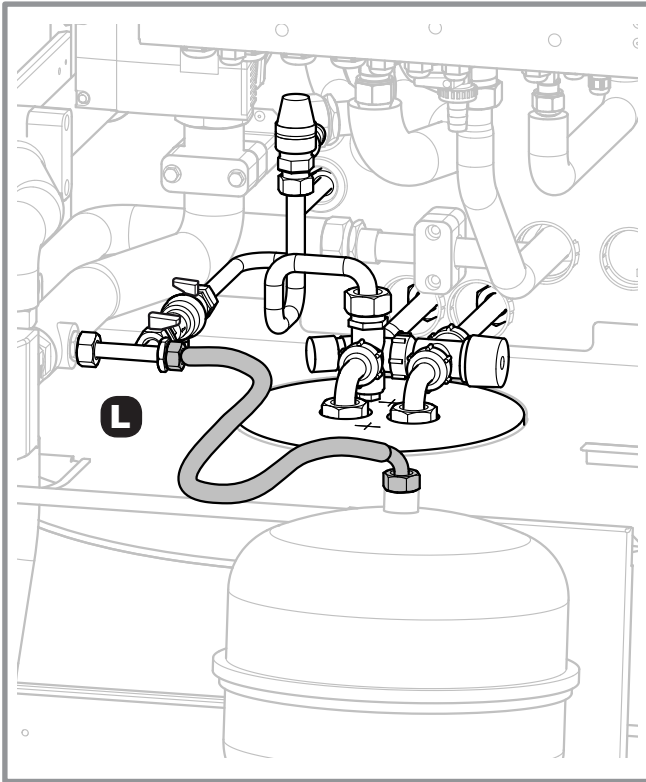
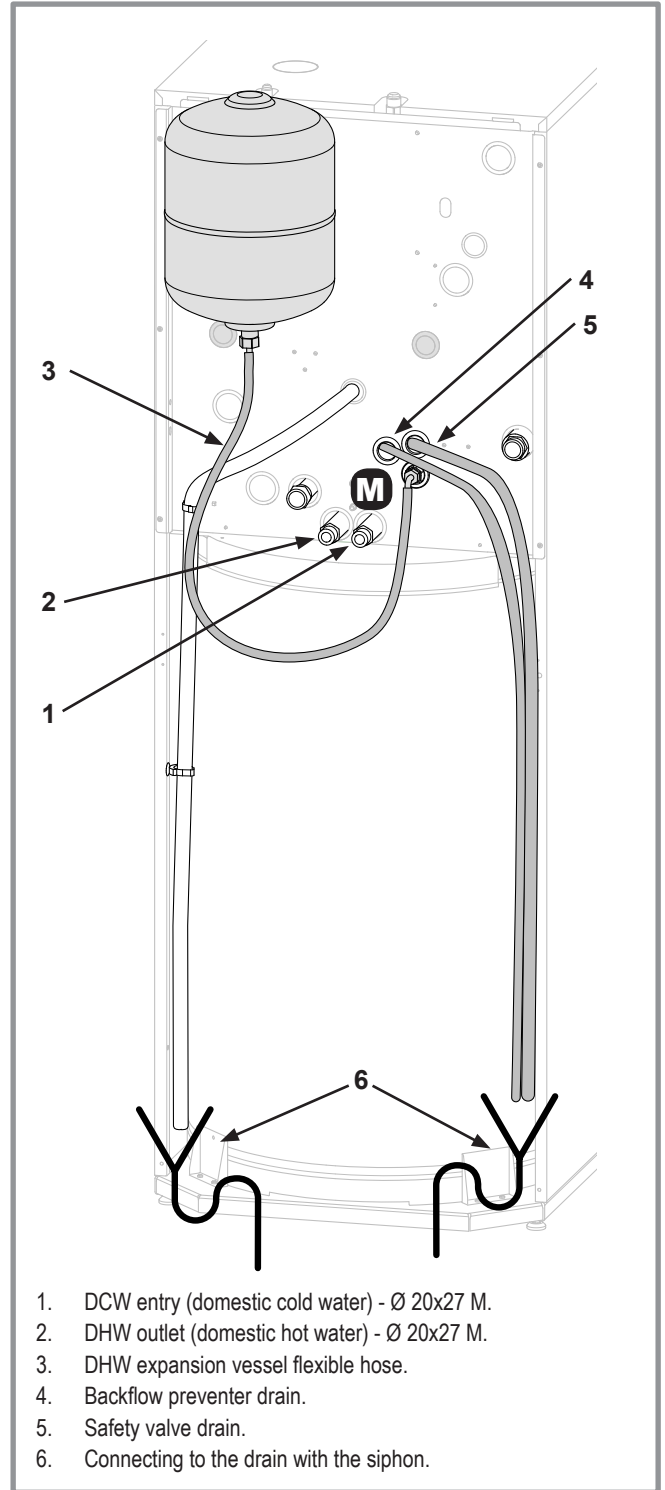

figure 5 - Connecting heating expansion vessel



1. DCW entry (domestic cold water) - Ø 20x27 M.
2. DHW outlet (domestic hot water) - Ø 20x27 M.
3. DHW expansion vessel flexible hose.
4. Backflow preventer drain.
5. Safety valve drain.
6. Connecting to the drain with the siphon.

figure 6 - Connecting DHW expansion vessel

Figure 5 & 6 :

- Connect sealed the heating expansion vessel on pipes kit (**L**).
- Connect the DHW expansion vessel on pipes kit using the supplied gasket (**M**).
- Connect the backflow preventer drains backflow preventer and safety valve in the sewer (Nr.6).

☞ **If the pressure distribution is greater than 4 bar, install a pressure reducer on the cold water inlet to ensure the proper functioning of DHW expansion vessel.**

2.2 Filling the installation

Figure 7 :

Open both backflow preventer valves (Nr. 4, figure 7) until the required pressure.

2.3 Temperature of DHW

Turn the valve on the mixer (Nr. 1, figure 7) to get the temperature of the hot water required.

The mixer allows you to adjust the hot water temperature in the range from 38°C to 55°C.

It is possible to change the maximum temperature (up to 65°C) to satisfy the specific requirements of the user. These modifications can be done only by a certified engineer :

- **To increase the maximum temperature :**

- Turn the dial (Nr. 1, figure 7) to (+) until it stops.
- Unscrew the screw to carefully unhook the dial without removing the gear.
- Turn the dial by step clockwise to (-) (¼ turn corresponds to about 7°C).
- Replace the dial gear.
- Tighten the screw and then turn the dial to max (+).

- **To reduce the maximum temperature in the reverse order:**

- Turn the dial to (-) until it stops.
- Once Unscrewed, turn the dial anti-clockwise to (+).

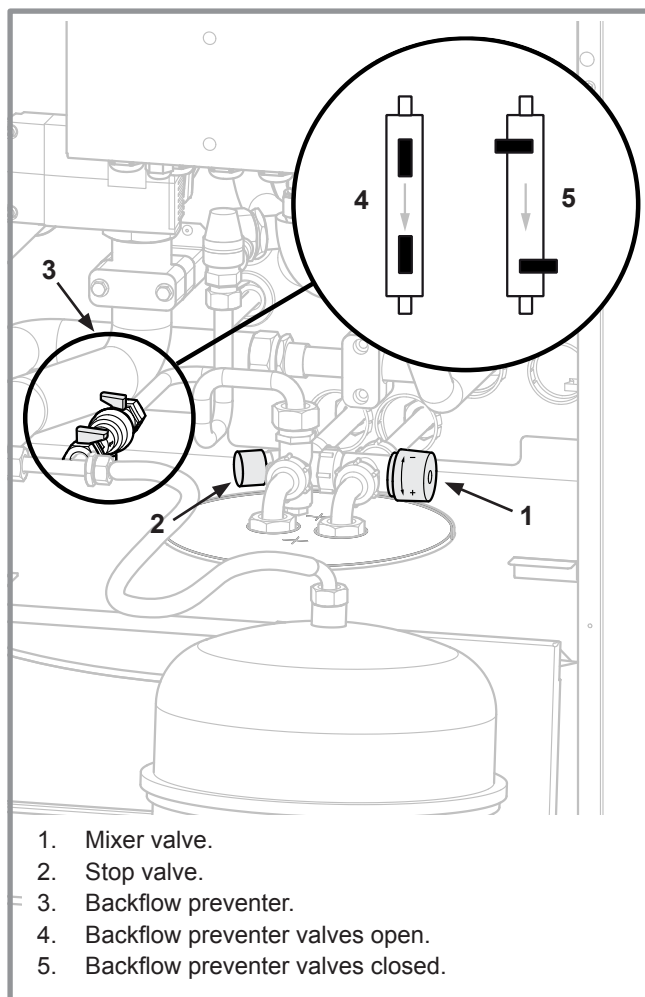

figure 7 - Backflow preventer valves and mixer

3 Instructions for user

3.1 Adding water of the hydraulic circuit

Open both backflow preventer valves (Nr. 4, figure 7). Add water until the hydraulic system pressure reaches 1.5 bar.

Close both backflow preventer valves (Nr. 5, figure 7).

☞ **The frequent water supply is at risk of scaling for the Heat exchanger and degrades performance and longevity of it.**

☞ **If frequent filling is required, have the installation's sealing checked.**

3.2 Closing the cold water supply

When closing the cold water supply is required, completely turn the "stop valve" button clockwise (Nr. 2, figure 7).

3.3 Temperature of DHW

Turn the valve on the mixer (Nr. 1, figure 7) to get the temperature of the hot water required (factory setting: 38°C to 55°C).

It is possible to change the maximum temperature (up to 65°C). Ask your dealer to change the maximum temperature to satisfy your needs.

4 Spare parts

When ordering spare parts, specify the appliance type and serial number, the name of the part and the part number.

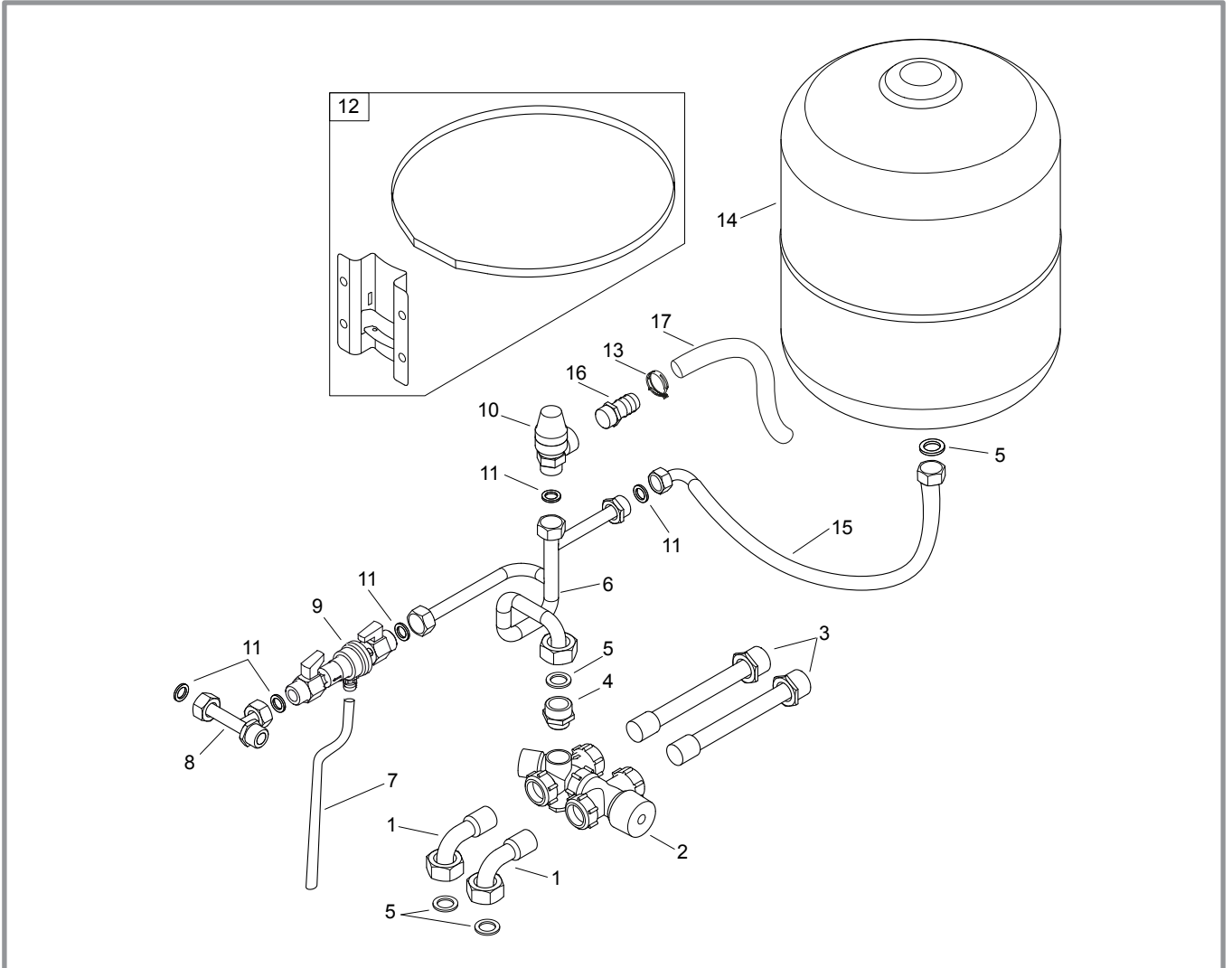

figure 8 - Spare parts

Nr	Code	Designation	Type	Qty
1	183166	Pipe		02
2	150172	Thermostatic mixer valve		01
3	183151	DHW pipe		02
4	149035	Reduced nipple	15-20	01
5	142442	Gasket	20x27	04
6	184153	Pipe		01
7	183170	Flexible hose		1,50 m
8	184154	Pipe		01
9	119526	Backflow preventer		01
10	174426	Safety valve		01
11	142723	Gasket	15x21	05
12	174670	Expansion vessel support		01
13	110624	Collar	22-23	01
14	188242	Expansion vessel	18 liters	01
15	183169	Flexible hose		01
16	123228	End		01
17	182400	Flexible hose	Ø 16	1,40 m



This appliance is marked with this symbol. This means that electrical and electronic products shall not be mixed with general household waste. European Community countries(*), Norway, Iceland and Liechtenstein should have a dedicated collection system for these products. Do not try to dismantle the system yourself as this could have harmful effects on your health and on the environment. The dismantling and treatment of refrigerant, oil and other parts must be done by a qualified installer in accordance with relevant local and national regulations. This appliance must be treated at a specialized treatment facility for re-use, recycling and other forms of recovery and shall not be disposed of in the municipal waste stream. Please contact the installer or local authority for more information.
* subject to the national law of each member state

Date of installation :

Contact of your heating technician or your after-sales service.